

Installer manual
NIBE F1255
Ground source heat pump

Quick guide

Navigation

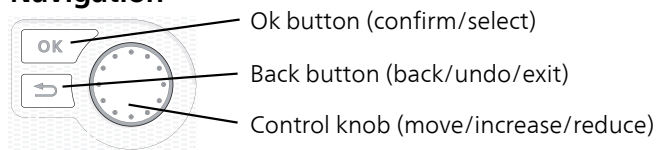

A detailed explanation of the button functions can be found on page 38.

How to scroll through menus and make different settings is described on page 40.

Set the indoor climate

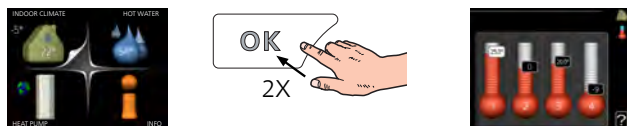

The mode for setting the indoor temperature is accessed by pressing the OK button twice, when in the start mode in the main menu.

Increase hot water volume



To temporarily increase the amount of hot water, first turn the control knob to mark menu 2 (water droplet) and then press the OK button twice.

Table of Contents

1 Important information _____	4	9 Service _____	54
Safety information _____	4	Service actions _____	54
2 Delivery and handling _____	6	10 Disturbances in comfort _____	60
Transport _____	6	Info-menu _____	60
Assembly _____	6	Manage alarm _____	60
Supplied components _____	7	Troubleshooting _____	60
Removing the covers _____	7	11 Accessories _____	62
Removing parts of the insulation _____	8	12 Technical data _____	64
3 The heat pump design _____	9	Dimensions and setting-out coordinates _____	64
General _____	9	Technical specifications _____	65
Distribution boxes _____	11	Energy labelling _____	71
Cooling section _____	12	Item register _____	82
4 Pipe connections _____	14	Contact information _____	87
General _____	14		
Dimensions and pipe connections _____	15		
Brine side _____	15		
Heating medium side _____	16		
Water heater _____	16		
Docking alternatives _____	16		
5 Electrical connections _____	19		
General _____	19		
Connections _____	21		
Settings _____	23		
Optional connections _____	26		
Connecting accessories _____	30		
6 Commissioning and adjusting _____	32		
Preparations _____	32		
Filling and venting _____	32		
Start guide _____	33		
Post adjustment and venting _____	34		
Setting the cooling/heating curve _____	36		
7 Control - Introduction _____	38		
Display unit _____	38		
Menu system _____	39		
8 Control - Menus _____	42		
Menu 1 - INDOOR CLIMATE _____	42		
Menu 2 - HOT WATER _____	42		
Menu 3 - INFO _____	42		
Menu 4 - HEAT PUMP _____	43		
Menu 5 - SERVICE _____	44		

1 Important information

Safety information

This manual describes installation and service procedures for implementation by specialists.

The manual must be left with the customer.

This appliance can be used by children aged from 8 years and above and persons with reduced physical, sensory or mental capabilities or lack of experience and knowledge if they have been given supervision or instruction concerning use of the appliance in a safe way and understand the hazards involved. Children shall not play with the appliance. Cleaning and user maintenance shall not be made by children without supervision.

Rights to make any design or technical modifications are reserved.

©NIBE 2017.

Symbols



NOTE

This symbol indicates danger to person or machine.



Caution

This symbol indicates important information about what you should observe when maintaining your installation.



TIP

This symbol indicates tips on how to facilitate using the product.

Marking

CE The CE mark is obligatory for most products sold in the EU, regardless of where they are made.

IP21 Classification of enclosure of electro-technical equipment.



Danger to person or machine.



Read the User Manual.

Serial number

The serial number can be found at the bottom right of the front cover and in the info menu (menu 3.1) and on the type plate (PF1).

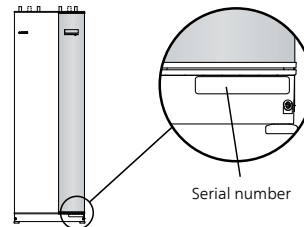

Caution

You need the product's ((14 digit) serial number for servicing and support.

Recovery



Leave the disposal of the packaging to the installer who installed the product or to special waste stations.



Do not dispose of used products with normal household waste. It must be disposed of at a special waste station or dealer who provides this type of service.

Improper disposal of the product by the user results in administrative penalties in accordance with current legislation.

Environmental information

This unit contains a fluorinated greenhouse gas that is covered by the Kyoto agreement.

F-Gas Regulation (EU) No. 517/2014

The equipment contains R407C, a fluorinated greenhouse gas with a GWP value (Global Warming Potential) of 1,774. Do not release R407C into the atmosphere.

Inspection of the installation

Current regulations require the heating installation to be inspected before it is commissioned. The inspection must be carried out by a suitably qualified person. In addition, fill in the page for the installation data in the User Manual.

✓	Description	Notes	Signature	Date
Brine (page 15)				
	System flushed			
	System vented			
	Antifreeze			
	Level/Expansion vessel			
	Filterball (particle filter)			
	Safety valve			
	Shut off valves			
	Circulation pump setting			
Heating medium (page 16)				
	System flushed			
	System vented			
	Expansion vessel			
	Filterball (particle filter)			
	Safety valve			
	Shut off valves			
	Circulation pump setting			
Electricity (page 19)				
	Connections			
	Main voltage			
	Phase voltage			
	Fuses heat pump			
	Fuses property			
	Outside sensor			
	Room sensor			
	Current sensor			
	Safety breaker			
	Earth circuit-breaker			
	Setting of emergency mode thermostat			

2 Delivery and handling

Transport

F1255 should be transported and stored vertically in a dry place. When being moved into a building, F1255 may be leant back 45°.



Caution

The product can be tail heavy.

Remove the outer panels in order to protect them when moving in confined spaces inside buildings.

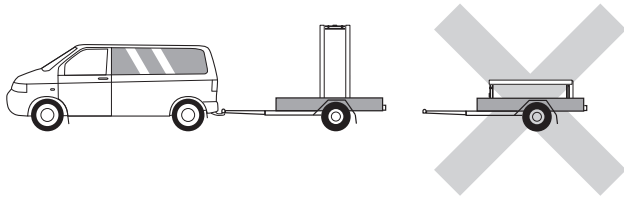

Extracting the cooling module

To simplify transport and service, the heat pump can be separated by pulling the cooling module out from the cabinet.

See page 56 for instructions about the separation.

Assembly

- Position F1255 on a fixed foundation that can take the weight of the heat pump. Use the product's adjustable feet to obtain a horizontal and stable set-up.

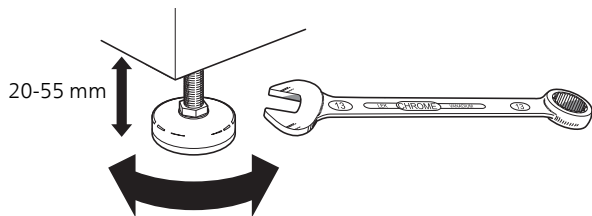

- Because water comes from F1255, the area where the heating pump is located must be equipped with floor drainage.
- Install with its back to an outside wall, ideally in a room where noise does not matter, in order to eliminate noise problems. If this is not possible, avoid placing it against a wall behind a bedroom or other room where noise may be a problem.
- Wherever the unit is located, walls to sound sensitive rooms should be fitted with sound insulation.
- Route pipes so they are not fixed to an internal wall that backs on to a bedroom or living room.

Installation area

Leave a free space of 800 mm in front of the product. Approx. 50 mm free space is required on each side, to remove the side panels (see image). The panels do not need to be removed during service. All service on F1255 can be carried out from the front. Leave space between the heat pump and the wall behind (and any routing of supply cables and pipes) to reduce the risk of any vibration being propagated.

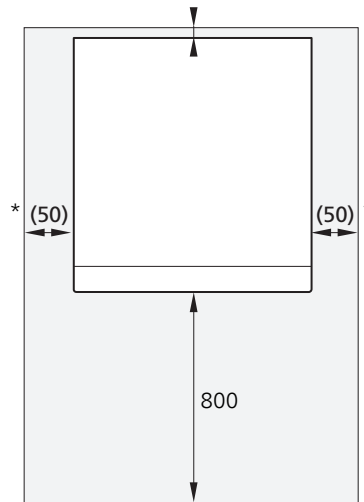

* A normal installation needs 300–400 mm (any side) for connection equipment, i.e. level vessel, valves and electrical equipment.

Supplied components

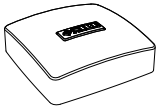

Outside sensor
1 x

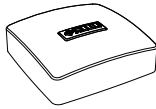

Room sensor
1 x



O-rings
8 x

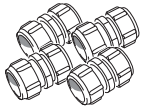

Compression ring
couplings

6 kW

2 x (ø28 x G25)
2 x (ø22 x G20)

12/16 kW

4 x (ø28 x G25)

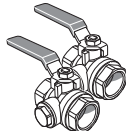

Filterball

6 kW

1 x G1
1 x G3/4

12/16 kW

1 x G1
1 x G1 1/4

In Italy and the DACH countries, the following components are not enclosed.



Current sensor
3 x



Safety valve
0.3 MPa (3 bar)
1 x

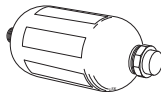

Level vessel
1 x

Location

The kit of supplied items is placed in packaging on top of the heat pump.

Removing the covers

Front cover

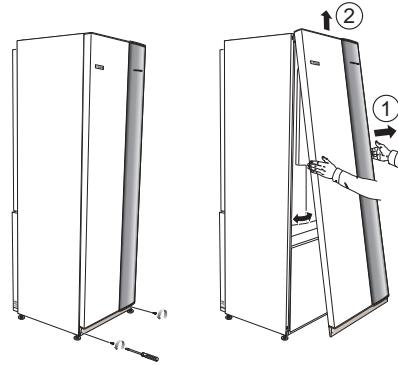

1. Remove the screws from the lower edge of the front panel.
2. Lift the panel out at the bottom edge and up.

Side covers

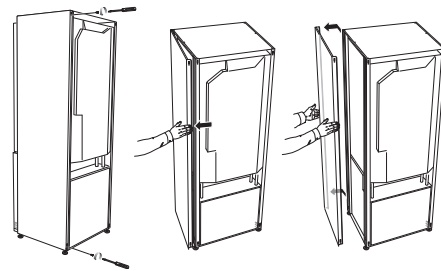

The side covers can be removed to facilitate the installation.

1. Remove the screws from the upper and lower edges.
2. Twist the cover slightly outward.
3. Move the hatch outwards and backwards.
4. Assembly takes place in the reverse order.

Removing parts of the insulation

Parts of the insulation can be removed to facilitate the installation.

Insulation, top

1. Disconnect the cable from the motor and remove the motor from the shuttle valve as illustrated.

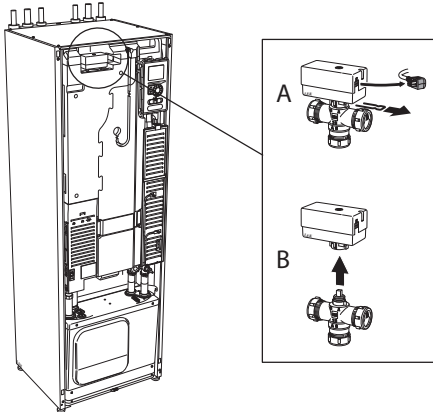

2. Grip the handle and pull straight out as illustrated.

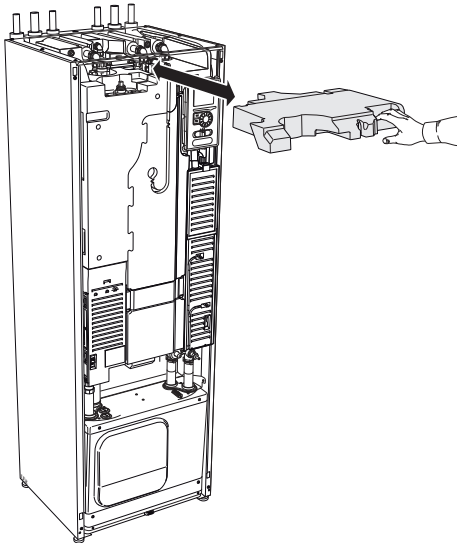

Insulation, immersion heater

NOTE

Electrical installation and service must be carried out under the supervision of a qualified electrician. Electrical installation and wiring must be carried out in accordance with the stipulations in force.

1. Remove the cover for the junction box according to the description on page 19.
2. Grip the handle and pull the insulation carefully towards you as illustrated.

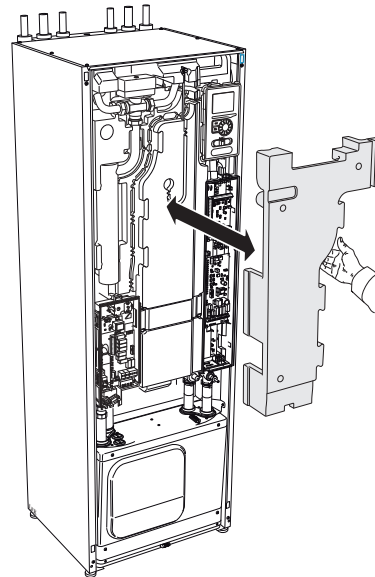

3 The heat pump design

General

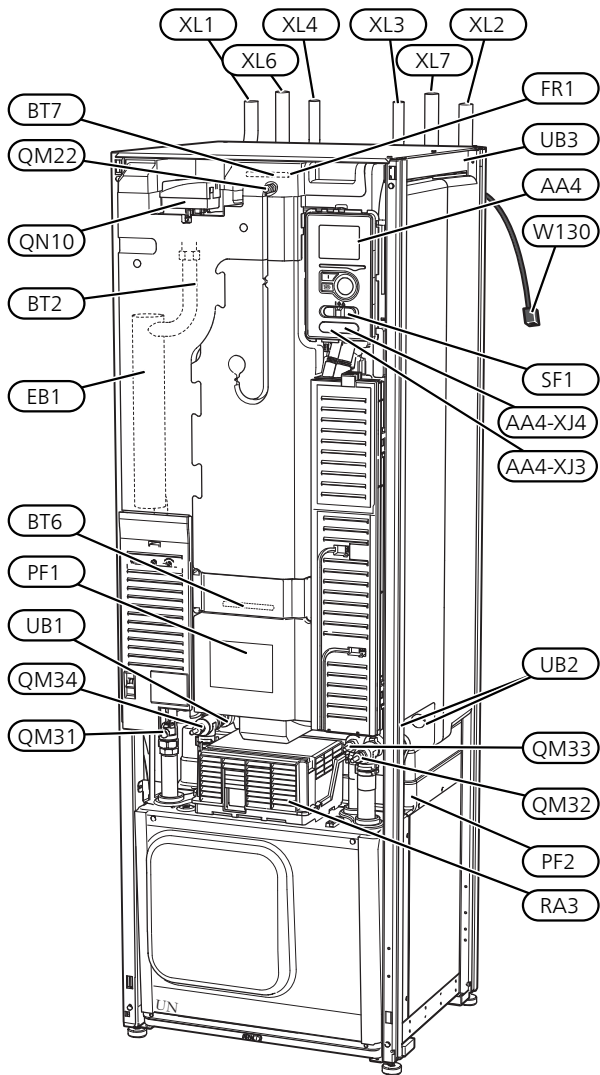

View from behind

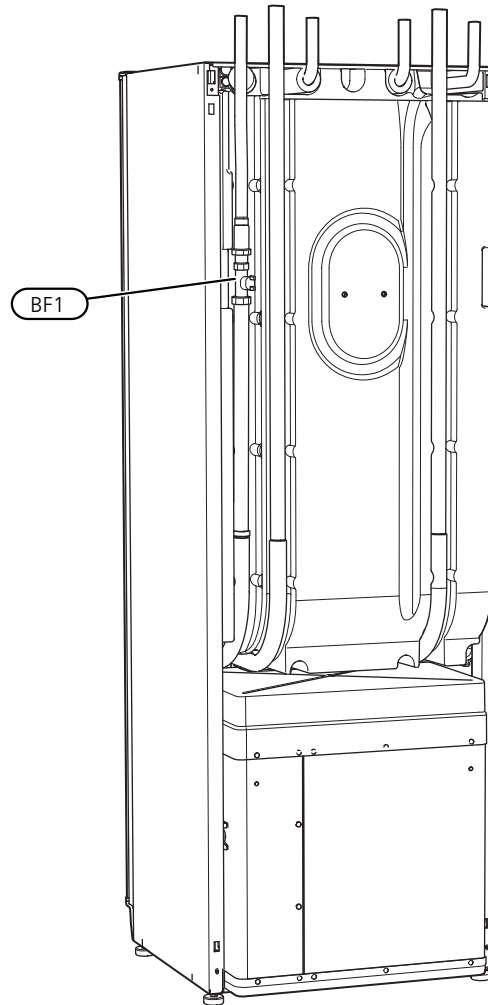

View from above

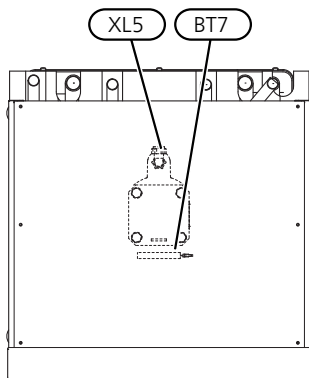

Pipe connections

XL1	Connection, heating medium flow
XL2	Connection, heating medium return
XL3	Connection, cold water
XL4	Connection, hot water
XL5	Connection, HWC*
XL6	Connection, brine in
XL7	Connection, brine out

* Only heat pumps with enamelled or stainless steel vessel.

HVAC components

QM22	Venting, coil
QM31	Shut-off valve, heating medium flow
QM32	Shut off valve, heating medium return
QM33	Shut off valve, brine out
QM34	Shut-off valve, brine in
QN10	Shuttle valve, climate system/water heater

Sensors etc.

BF1	Flow meter**
BT1	Outdoor temperature sensor*
BT2	Temperature sensors, heating medium flow
BT6	Temperature sensor, hot water charging
BT7	Temperature sensor, hot water top

**Only heat pumps with energy meter

* Not illustrated

Electrical components

AA4	Display unit
	AA4-XJ3 USB socket
	AA4-XJ4 Service outlet (No function)
EB1	Immersion heater
FR1	El. anode*
RA3	Choke**
SF1	Switch
W130	Network cable for Uplink

* Only heat pump with enamelled vessel.

** Only for F1255-12 kW 3X400V.

Miscellaneous

PF1	Rating plate
PF2	Type plate, cooling section
UB1	Cable gland, incoming electricity
UB2	Cable gland
UB3	Cable gland, rear side, sensor

Designations in component locations according to standard IEC 81346-1 and 81346-2.

Distribution boxes

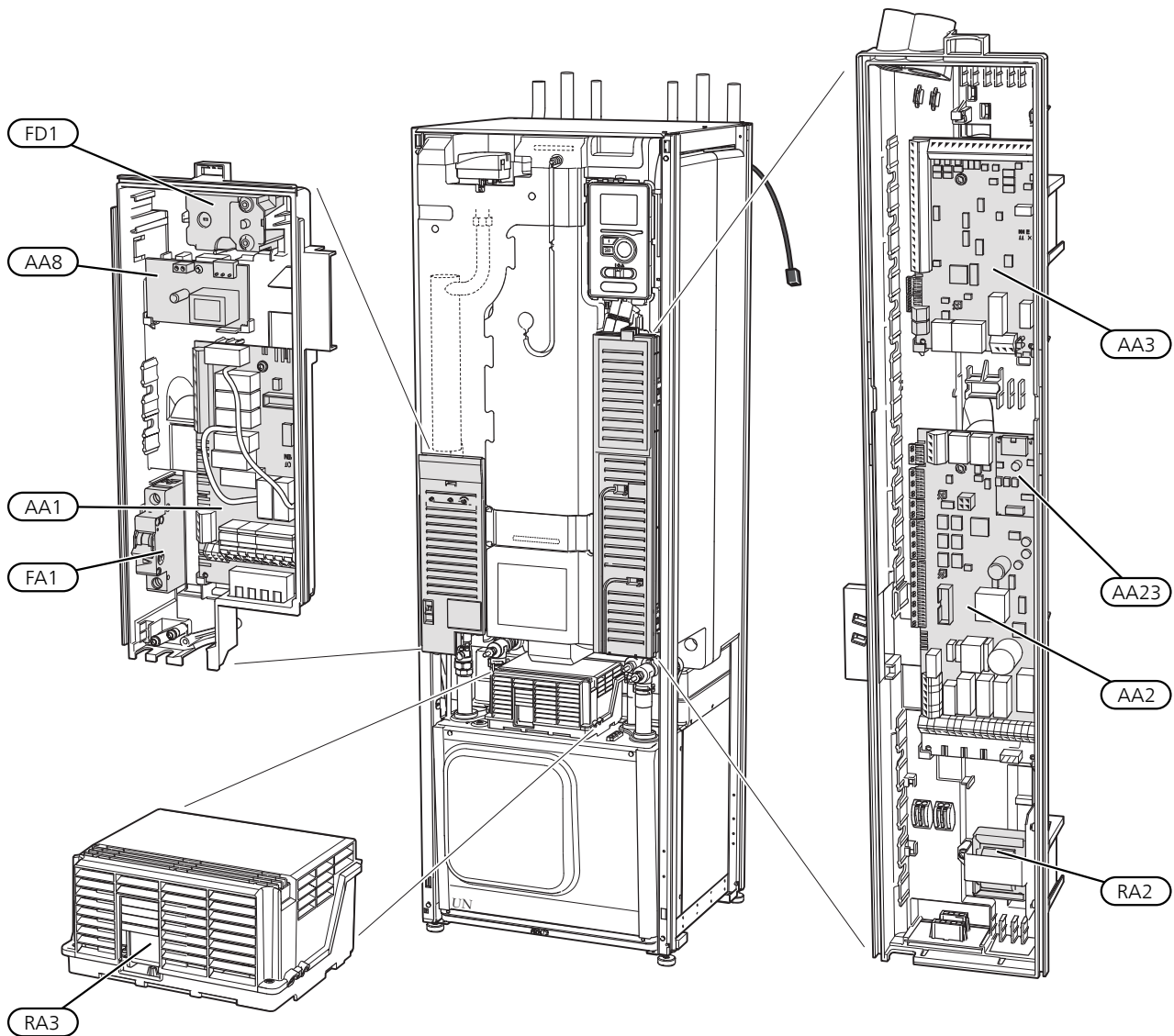

Electrical components

AA1	Immersion heater card
AA2	Base card
AA3	Input circuit board
AA8	Electrical anode board*
AA23	Communication board
FA1	Miniature circuit-breaker
FD1	Temperature limiter/Emergency mode thermostat
RA2	Choke**
RA3	Choke**

* Only heat pump with enamelled vessel.

** Only for F1255-12 kW 3X400V.

Designations in component locations according to standard IEC 81346-1 and 81346-2.

Cooling section

6 kW

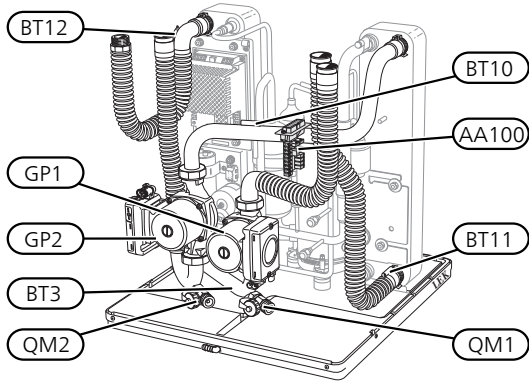

1x230 V 12 kW
3x230 V 12 kW

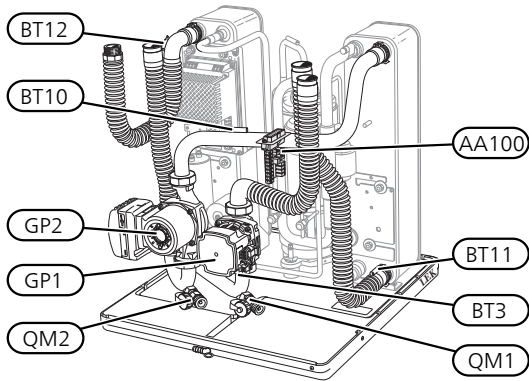

3x400 V 12 kW

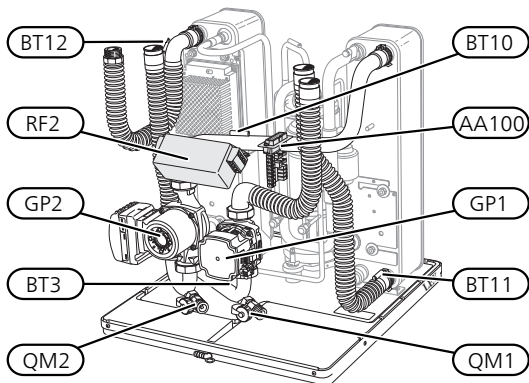

16 kW

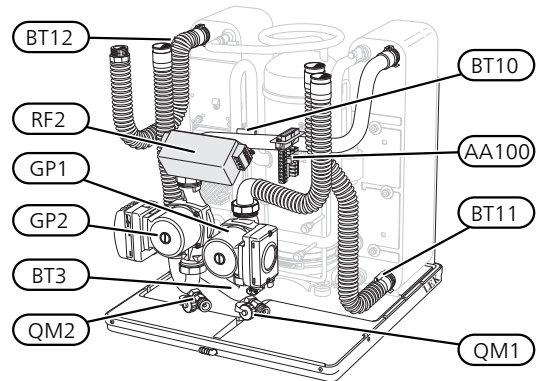

6 kW

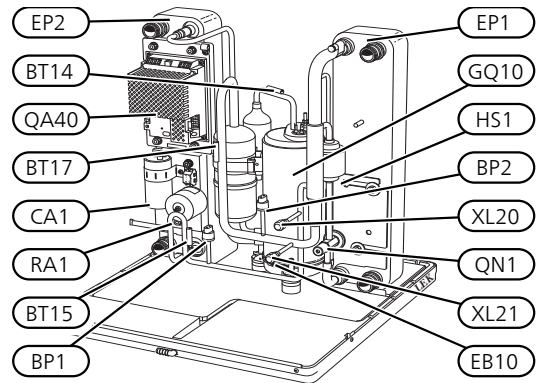

1x230 V 12 kW
3x230 V 12 kW

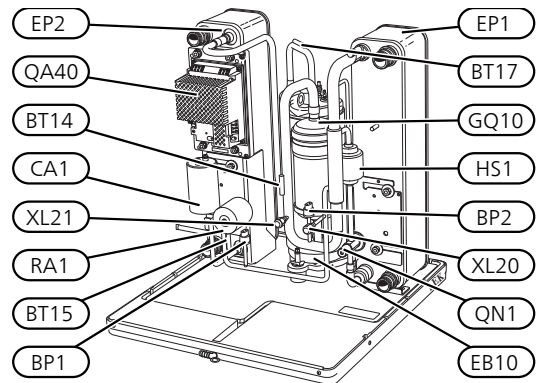

3x400 V 12 kW

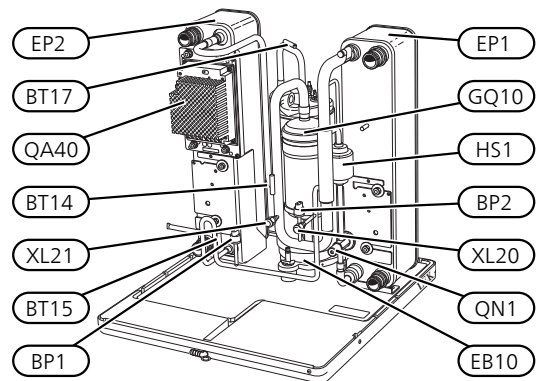

3x400 V 16 kW

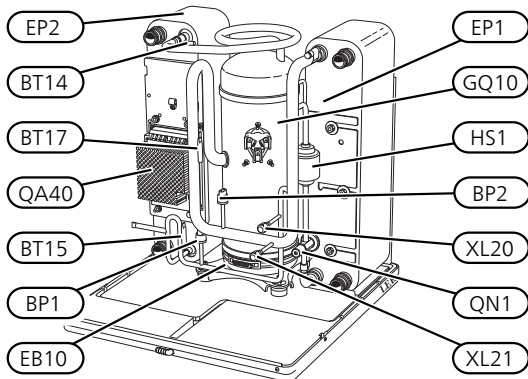

Pipe connections

- XL20 Service connection, high pressure
- XL21 Service connection, low pressure

HVAC components

- GP1 Circulation pump
- GP2 Brine pump
- QM1 Drainage, climate system
- QM2 Draining, brine side

Sensors etc.

- BP1 High pressure pressostat
- BP2 Low pressure pressostat
- BT3 Temperature sensors, heating medium return
- BT10 Temperature sensor, brine in
- BT11 Temperature sensor, brine out
- BT12 Temperature sensor, condenser supply line
- BT14 Temperature sensor, hot gas
- BT15 Temperature sensor, fluid pipe
- BT17 Temperature sensor, suction gas

Electrical components

- AA100 Joint card
- CA1 Capacitor
- EB10 Compressor heater
- QA40 Inverter
- RA1 Choke
- RF2* EMC-filter

* Only 12 & 16 kW 3X400 V.

Cooling components

- EP1 Evaporator
- EP2 Condenser
- GQ10 Compressor
- HS1 Drying filter
- QN1 Expansion valve

Designations in component locations according to standard IEC 81346-1 and 81346-2.

4 Pipe connections

General

Pipe installation must be carried out in accordance with current norms and directives. F1255 can operate with a return temperature of up to 58 °C and an outgoing temperature from the heat pump of 70 (65 °C with only the compressor).

F1255 is not equipped with external shut off valves; these must be installed to facilitate any future servicing.



Caution

Ensure that incoming water is clean. When using a private well, it may be necessary to supplement with an extra water filter.



Caution

Any high points in the climate system, must be equipped with air vents.



NOTE

The pipe system needs to be flushed out before the heat pump is connected so that debris cannot damage component parts.

Symbol key

Symbol	Meaning
	Shut-off valve
	Non-return valve
	Mixing valve
	Shunt / shuttle valve
	Safety valve
	Temperature sensor
	Pressure gauge
	Circulation pump
	Particle filter
	Filterball (ball valve with integrated particle filter)
	Compressor
	Expansion vessel
	Level vessel
	Heat exchanger

System diagram

F1255 consists of a heat pump, water heater, electrical module, circulation pumps and a control system. F1255 is connected to the brine and heating medium circuits.

In the heat pump evaporator, the brine (water mixed with anti-freeze, glycol or ethanol) releases its energy to the refrigerant, which is vaporised in order to be compressed in the compressor. The refrigerant, of which the temperature has now been raised, is passed to the condenser where it gives off its energy to the heating medium circuit and, if necessary, to the water heater. If there is a greater need for heating/hot water than the compressor can provide there is an integrated immersion heater.

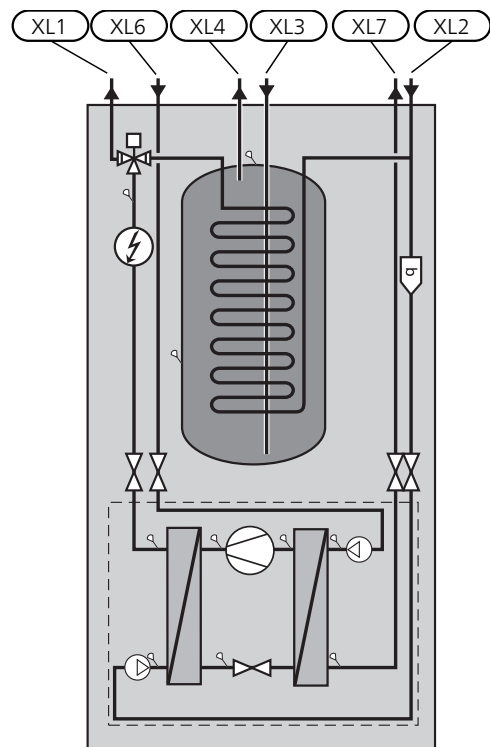

- XL1 Connection, heating medium flow
- XL2 Connection, heating medium return
- XL3 Connection, cold water
- XL4 Connection, hot water
- XL6 Connection, brine in
- XL7 Connection, brine out

Dimensions and pipe connections

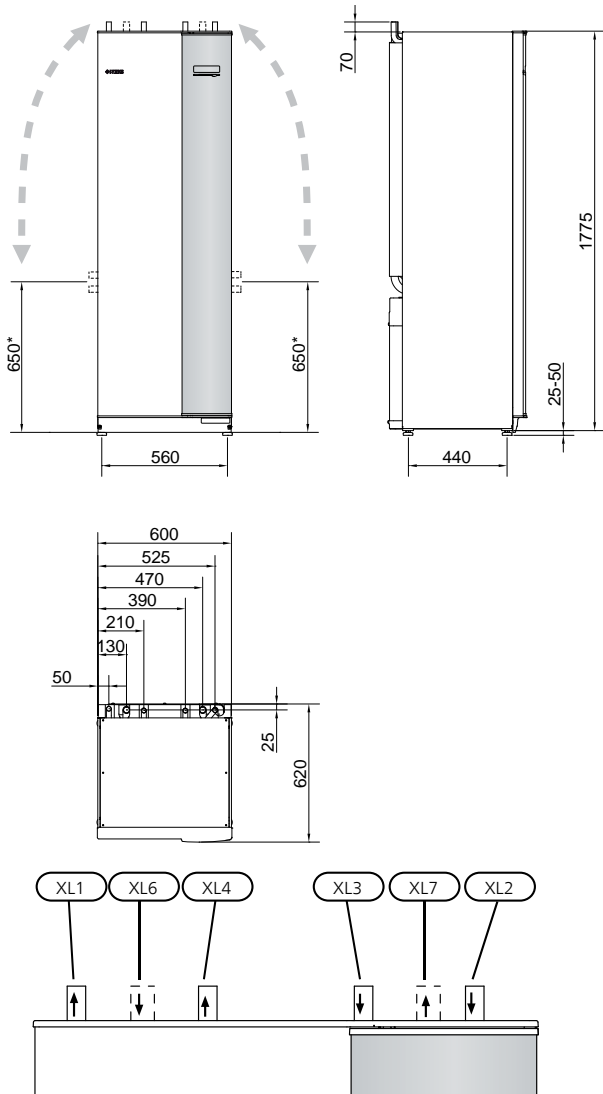

Pipe dimensions

Connection		6	12	16
		kW	kW	kW
(XL1)/(XL2) Heating medium flow/return ext Ø	(mm)	22		28
(XL3)/(XL4) Cold/hot water Ø	(mm)		22	
(XL6)/(XL7) Brine in/out ext Ø	(mm)		28	

Brine side

Collector



Caution

The length of the collector hose varies depending on the rock/soil conditions, climate zone and on the climate system (radiators or under-floor heating) and the heating requirement of the building. Each installation must be sized individually.

Max length per coil for the collector should not exceed 400 m.

In those cases where it is necessary to have several collectors, these should be connected in parallel with the possibility of adjusting the flow of the relevant coil.

For surface soil heat, the hose should be buried at a depth determined by local conditions and the distance between the hoses should be at least 1 metre.

For several bore holes, the distance between the holes must be determined according to local conditions.

Ensure the collector hose rises constantly towards the heat pump to avoid air pockets. If this is not possible, airvents should be used.

Because the temperature of the brine system can fall below 0 °C, it must be protected against freezing down to -15 °C. When making the volume calculation, use 1 litres of ready mixed brine per metre of collector hose (applies when using PEM-hose 40x2.4 PN 6.3) as a guide value.

Side connection

It is possible to angle the brine connections, for connection to the side instead of top connection.

To angle out a connection:

1. Disconnect the pipe at the top connection.
2. Angle the pipe in the desired direction.
3. If necessary, cut the pipe to the desired length.

* Can be angled for side connection.

Connecting the brine side

- Insulate all indoor brine pipes against condensation.
- The level vessel must be installed at the highest point in the brine system, on the incoming pipe before the brine pump (Alt. 1).

If the level vessel cannot be placed at the highest point, an expansion vessel must be used (Alt. 2).

NOTE

Note that condensation may drip from the level vessel. Position the vessel so that this does not harm other equipment.

- Details of the antifreeze used must be shown on the level vessel.
- Install the enclosed safety valve under the level vessel as illustrated. The entire length of the overflow water pipe from the safety valve must be inclined to prevent water pockets and must also be frost-free.
- Install shut off valves as close to the heat pump as possible.
- Fit the enclosed filterball on the incoming pipe.

In the case of connection to an open groundwater system, an intermediate frost-protected circuit must be provided, because of the risk of dirt and freezing in the evaporator. This requires an extra heat exchanger.

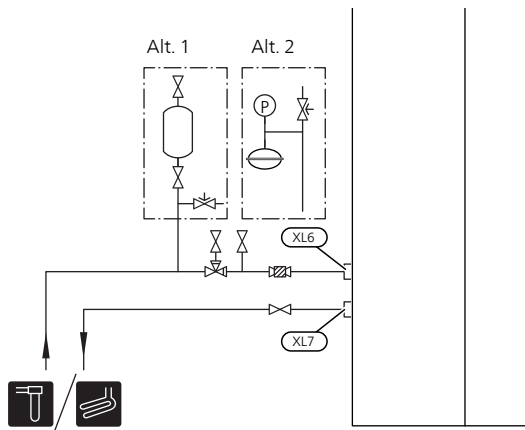

Heating medium side

Connecting the climate system

A climate system is a system that regulates indoor comfort with the help of the control system in F1255 and for example radiators, underfloor heating/cooling, fan convectors etc.

- Install all necessary safety devices, shut-off valves (as close to the heat pump as possible) and the enclosed filterball.
- The safety valve must have a maximum 0.25 MPa (2.5 bar) opening pressure and be installed on the heating medium return as illustrated. The entire length of the overflow water pipe from the safety valves must be inclined to prevent water pockets and must also be frost proof.

- When connecting to a system with thermostats on all radiators, a relief valve must be fitted, or some of the thermostats must be removed to ensure sufficient flow.

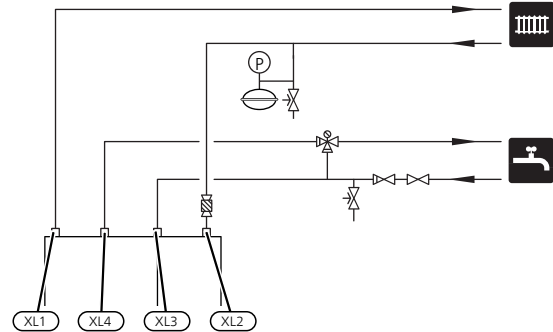

Water heater

Connecting the hot water heater

- The hot water heater in the heat pump must be supplied with necessary set of valves.
- The mixing valve must be installed if the setting is changed so that the temperature can exceed 60 °C.
- The setting for hot water is made in menu 5.1.1.
- The safety valve must have a maximum opening pressure of 1.0 MPa (10.0 bar) and be installed on the incoming domestic water line as illustrated. The entire length of the overflow water pipe from the safety valve must be inclined to prevent water pockets and must also be frost-free.

Docking alternatives

F1255 can be connected in several different ways, some of which are shown below.

Further option information is available at nibe.eu and in the respective assembly instructions for the accessories used. See page 62 for a list of the accessories that can be used with F1255.

Buffer vessel

If the climate system volume is too small for the heat pump output, the radiator system can be supplemented with a buffer vessel, for example NIBE UKV.

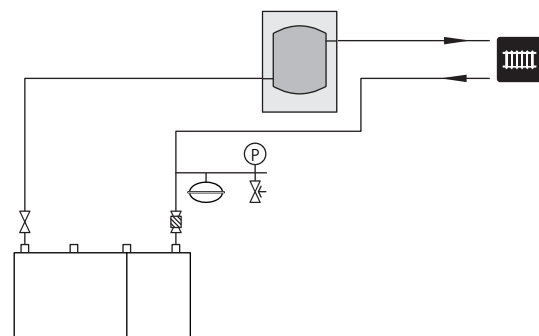

Extra electric hot water heater

The heat pump should be supplemented with an electric water heater, if a hot tub or other significant consumer of hot water is installed.

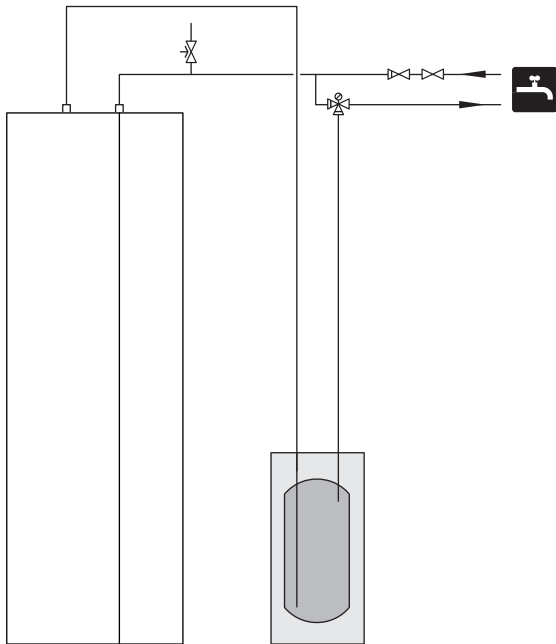

Ground water system

An intermediate heat exchanger is used to protect the heat pump's exchanger from dirt. The water is released into a buried filtration unit or a drilled well. See page 30 for more information about connecting a ground water pump.

If this docking alternative is used, "min. brine out" in menu 5.1.7 "br pmp al set." must be changed to a suitable value to prevent freezing in the heat exchanger.

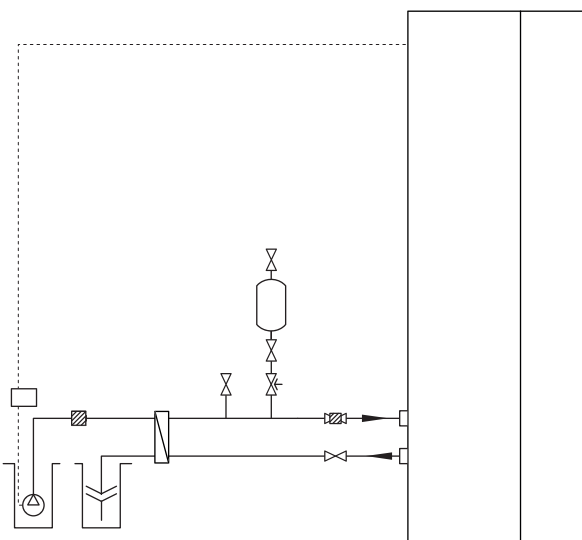

Ventilation recovery

The installation can be supplemented with the exhaust air module FLM to enable ventilation recovery.

- Pipes and other cold surfaces must be insulated with diffusion-proof material to prevent condensation.
- The brine system must be supplied with a pressure expansion vessel (CM3). If there is a level vessel (CM2) this should be replaced.

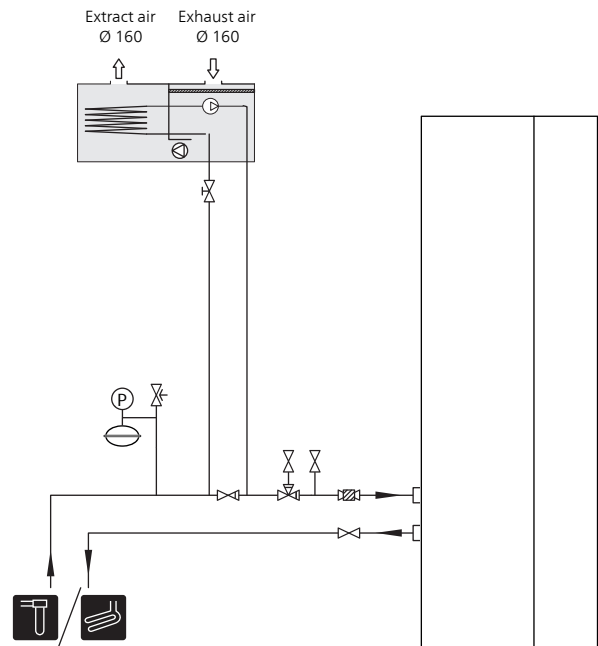

Free cooling

The accessory PCS 44 allows the connection of passive cooling, for example with fan coils. The cooling system is connected to the heat pump brine circuit, whereby cooling is supplied from the collector via a circulation pump and shunt valve.

- Pipes and other cold surfaces must be insulated with diffusion-proof material to prevent condensation.
- Where the cooling demand is high, fan convectors with drip trays and drain connection are needed.
- The brine system must be supplied with a pressure expansion vessel (CM3). If there is a level vessel (CM2) this should be replaced.

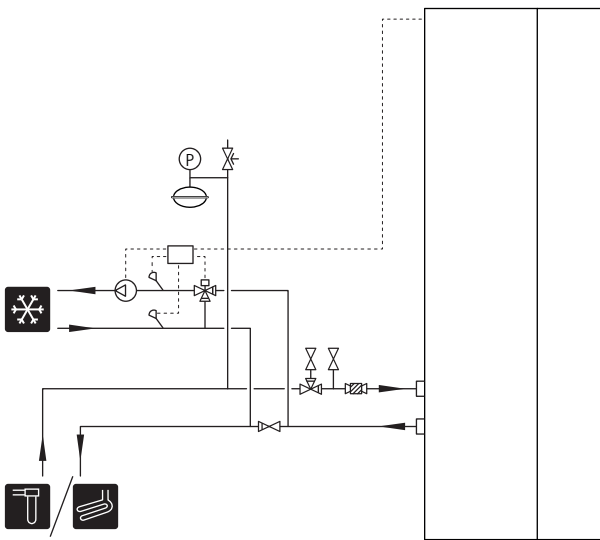

Underfloor heating system/preheating FTX

The external circulation pump is dimensioned for the under floor heating system's demand.

To ensure a heating supply during hot water production, the heating system can be supplemented with a NIBE UKV vessel, e.g. when there is a water coil in the FTX ventilation.

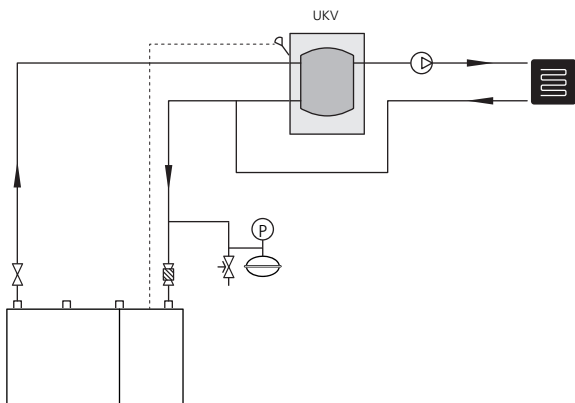

Two or more climate systems

In buildings with several climate systems that require different supply temperatures, the accessory ECS 40/ECS 41 can be connected. A shunt valve then lowers the temperature to the underfloor heating system, for example.

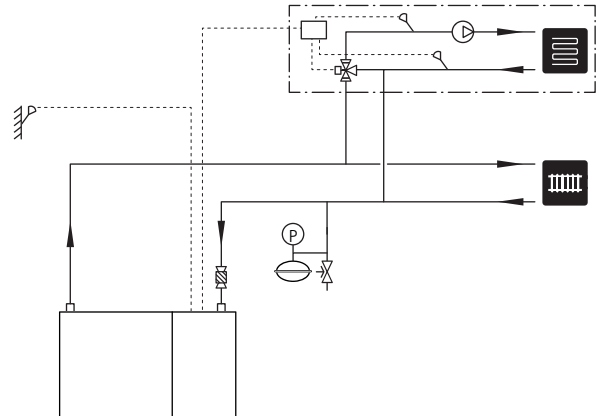

Pool

By supplementing the installation with the accessory POOL 40, pool heating is enabled in your climate unit.

During pool heating, the heating medium circulates between the F1255 and the pool exchanger using the heat pump's internal circulation pumps.

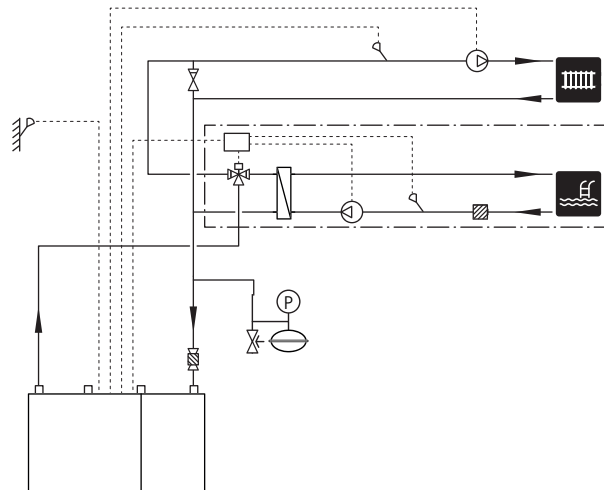

5 Electrical connections

General

All electrical equipment, except the outdoor sensors, room sensors and the current sensors are ready connected at the factory.

- Disconnect the heat pump before insulation testing the house wiring.
- If the building is equipped with an earth-fault breaker, F1255 should be equipped with a separate one.
- If a miniature circuit breaker is used this should have at least motor characteristic "C". See page 65 for fuse size.
- Electrical wiring diagrams for the heat pump, see separate installation handbook for electrical wiring diagrams.
- Communication and sensor cables to external connections must not be laid close to high current cables.
- The minimum area of communication and sensor cables to external connections must be 0.5 mm² up to 50 m, for example EKKX or LiYY or equivalent.
- When cable routing in F1255, cable grommets (e.g. UB1-UB3, marked in image) must be used. In UB1-UB3 the cables are inserted through the heat pump from the back to the front.



NOTE

The switch (SF1) must not be moved to "I" or "⚠" until the boiler has been filled with water. Component parts of the product can be damaged.



NOTE

Electrical installation and service must be carried out under the supervision of a qualified electrician. Cut the current with the circuit breaker before carrying out any servicing. Electrical installation and wiring must be carried out in accordance with the stipulations in force.



NOTE

Check the connections, main voltage and phase voltage before the machine is started, to prevent damage to the heat pump electronics.

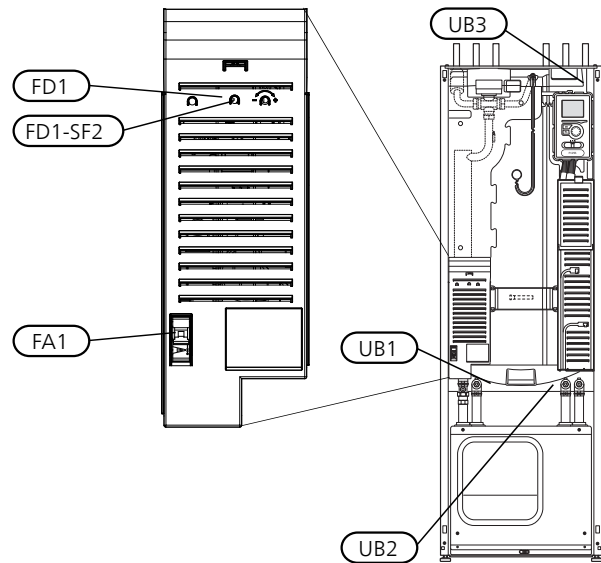

Miniature circuit-breaker

The heat pump operating circuit and some of its internal components are internally fused by a miniature circuit breaker (FA1).

Temperature limiter

The temperature limiter (FD1) cuts the power to the electric additional heat if the temperature exceeds 89°C and is reset manually.

Resetting

The temperature limiter (FD1) is accessible behind the front cover. Reset the temperature limiter by pressing the button (FD1-SF2) using a small screwdriver.

Accessibility, electrical connection

The plastic cap of the electrical boxes is opened using a screwdriver.



NOTE

The cover for the input card is opened without a tool.

Removing the cover, input circuit board

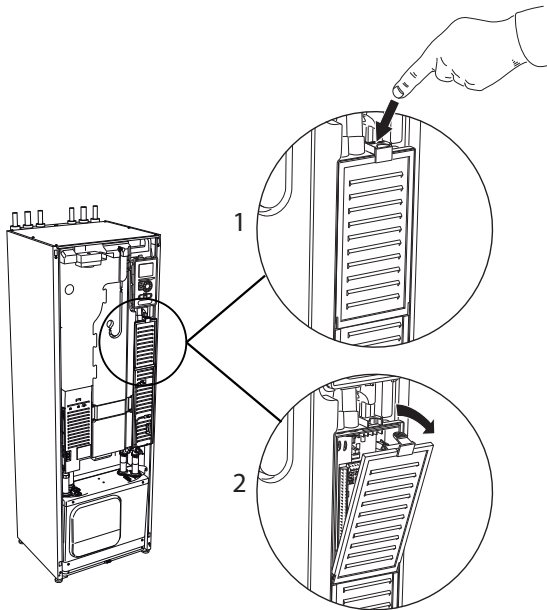

1. Push the catch down.
2. Angle out the cover and remove it.

Removing the cover, immersion heater circuit board

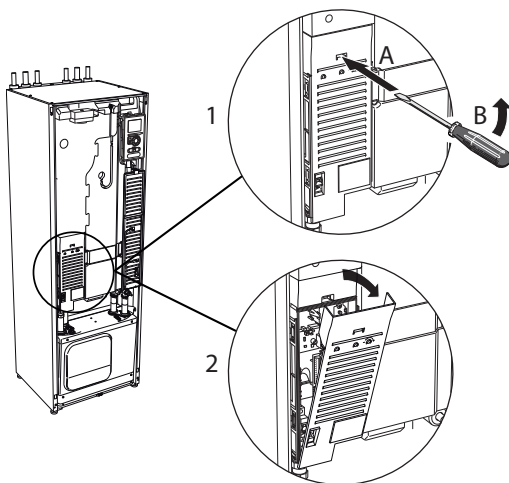

1. Insert the screwdriver (A) and pry the catch carefully downwards (B).
2. Angle out the cover and remove it.

Removing the cover, base board



Caution

To remove the cover for the base board, the cover for the input circuit board must first be removed.

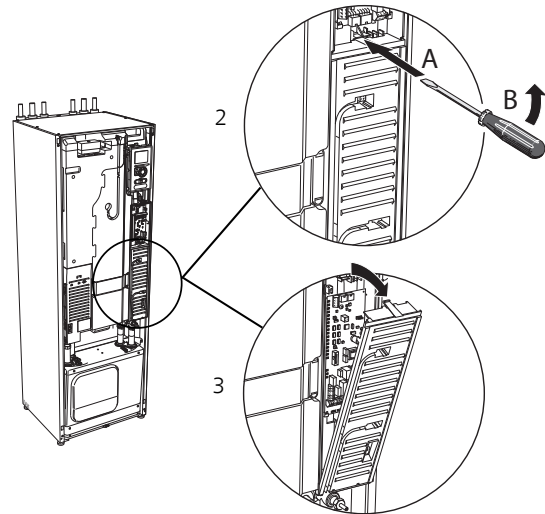
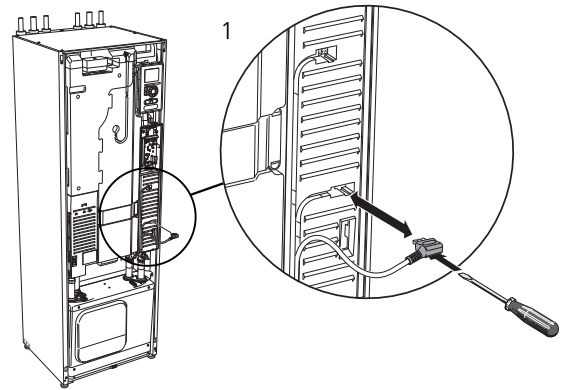

1. Disconnect the switches using a screwdriver.
2. Insert the screwdriver (A) and pry the catch carefully downwards (B).
3. Angle out the cover and remove it.

Cable lock

Use a suitable tool to release/lock cables in the heat pump terminal blocks.

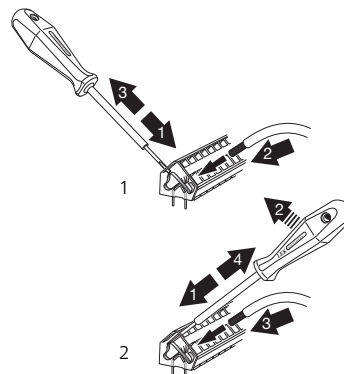

Connections



NOTE

To prevent interference, unshielded communication and/or sensor to external connections cables must not be laid closer than 20 cm to high voltage cable when cable routing.

Power connection

F1255 must be installed with a disconnection option on the supply cable. Minimum cable area must be sized according to the fuse rating used. Enclosed cable for incoming supply electricity is connected to terminal block X1 on the immersion heater board (AA1). All installations must be carried out in accordance with current norms and directives.

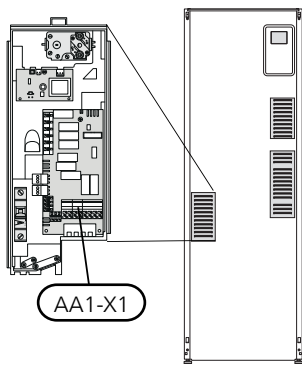

NOTE

F1255 is not reconnectable between 1-phase and 3-phase, neither is it reconnectable between 3x230V and 3x400V.

Connection 3x400V

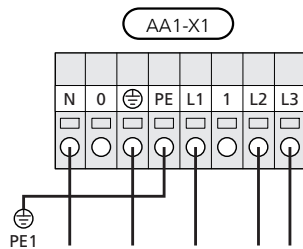

Connection 3x230V

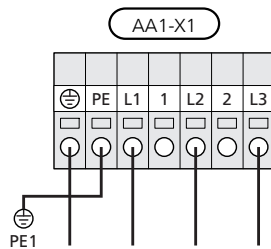

Connection 1x230V

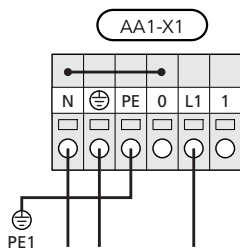

If separate supply to the compressor and immersion heater is required, see section "Switch for external blocking of addition and/or compressor" on page 28.

Tariff control

If the voltage to the immersion heater and/or the compressor disappears during a certain period, there must also be blocking via the AUX-input, see "Connection options - Possible selection for AUX inputs" page. 28

Connecting external operating voltage for the control system



NOTE

Only applies to power connection of 3x400V.



NOTE

Mark up any junction boxes with warnings for external voltage.

If you wish to connect external operating voltage for the control system to F1255 on the immersion heater circuit board (AA1) the edge connector at AA1:X2 must be moved to AA1:X9 (as illustrated).

Operating voltage (1x230V ~ 50Hz) is connected to AA1:X11 (as illustrated).

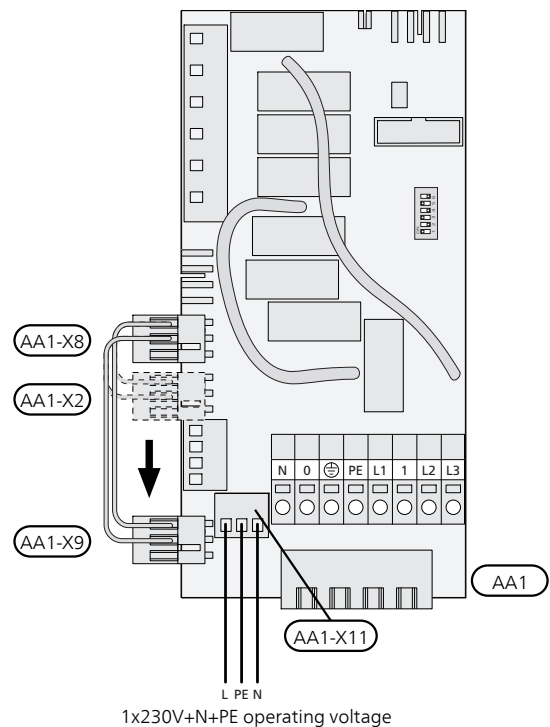

Connecting sensors

Connect the sensor(s) to terminal X6 on input board (AA3) according to the instructions below.

Outside sensor

Install the outdoor temperature sensor (BT1) in the shade on a wall facing north or north-west, so it is unaffected by the morning sun for example.

Connect the sensor to terminal block X6:1 and X6:2 on the input board (AA3). Use a twin core cable of at least 0.5 mm² cable area.

If a conduit is used it must be sealed to prevent condensation in the sensor capsule.

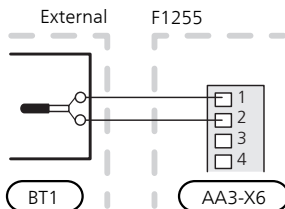
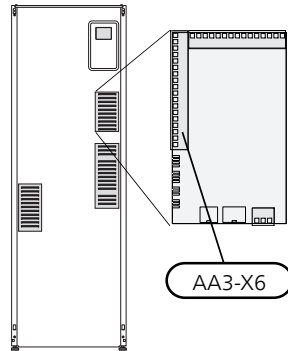

Temperature sensor, external flow line

If temperature sensor, external flow line (BT25) needs to be used, connect it to terminal block X6:5 and X6:6 on the input card (AA3). Use a 2 core cable of at least 0.5 mm² cable area.

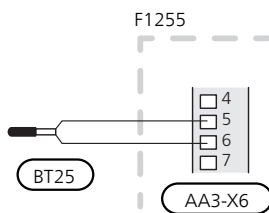

Room sensor

F1255 is supplied with a room sensor enclosed (BT50). The room sensor has a number of functions:

1. Shows current room temperature in the display on F1255.
2. Option of changing the room temperature in °C.
3. Provides the option of fine-tuning the room temperature.

Install the sensor in a neutral position where the set temperature is required. A suitable location is on a free inner wall in a hall approx. 1.5 m above the floor. It is important that the sensor is not obstructed from measuring the correct room temperature by being located, for example, in a recess, between shelves, behind a curtain, above or close to a heat source, in a draft from an external door or in direct sunlight. Closed radiator thermostats can also cause problems.

The heat pump operates without the sensor, but if one wishes to read off the accommodation's indoor temperature in F1255's display, the sensor must be installed. Connect the room sensor to X6:3 and X6:4 on the input board (AA3).

If the sensor is to be used to change the room temperature in °C and/or to fine-tune the room temperature, the sensor must be activated in menu 1.9.4.

If the room sensor is used in a room with underfloor heating, it should only have an indicative function, not control of the room temperature.

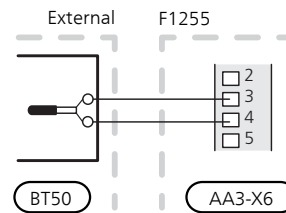

Caution

Changes of temperature in accommodation take time. For example, short time periods in combination with underfloor heating will not give a noticeable difference in room temperature.

Connecting external energy meter



NOTE

Connection of external energy meter requires version 35 or later on input board (AA3) as well as "display version" 7312 or later.

One or two energy meters (BE6, BE7) are connected to terminal block X22 and/or X23 on input board (AA3).

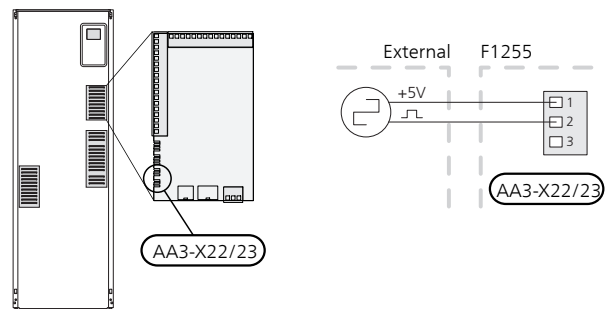

Activate the energy meter(s) in menu 5.2.4 and then set the desired value (energy per pulse) in menu 5.3.21.

Settings

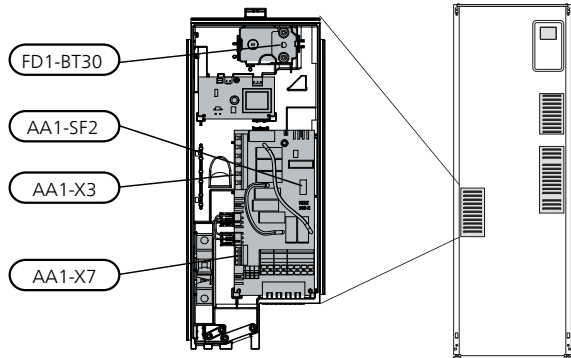

Electrical addition - maximum output

Number of steps, maximum electrical output and supply on connection for the immersion heater varies depending on model. See tables.

The electric additional heat may be restricted depending on the selected country.

F1255-6	Max	Number of connection steps
1x230V	4.5 kW	9
3x230V	4.5 kW	9
3x400V	6.5 kW	13

F1255-12	Max	Number of connection steps
1x230V	7 kW	7
3x230V	9 kW	4

F1255-12 & -16	Max (Factory setting)	Switchable to	Number of connection steps
3x400V	7 kW	9 kW	7 steps (4 steps if the immersion heater is switched to maximum 9 kW)

Setting max electrical output

Setting maximum output in the electric additional heat is done in menu 5.1.12.

The table displays the total phase current for the immersion heater at start up. If an immersion heater has already been started and is not used for its full capacity the values in the table can be changed because the control initially uses this immersion heater.

Switching to maximum electrical output



NOTE

This connection only applies for 3x400V for F1255-12 and -16.

If more than the maximum output (7 kW) for the immersion heater connected on delivery is needed, the heat pump can be switched to maximum 9 kW.

Move the white cable from terminal block X7:23 to terminal block X3:13 (the seal on the terminal block must be broken) on the immersion heater card (AA1).

3x400V V (maximum electrical output, connected upon delivery 7 kW for F1255-12 / -16)

Max electrical addition (kW)	Max phase current L1(A)	Max phase current L2(A)	Max phase current L3(A)
0	–	–	–
1	–	–	4.3
2	–	8.7	–
3	–	8.7	4.3
4	–	8.7	8.7
5	–	8.7	13.0
6	8.7	8.7	8.7
7	8.7	8.7	13.0

3x400V (maximum electrical output, switched to 9 kW for F1255-12 / -16.)

Max electrical addition (kW)	Max phase current L1(A)	Max phase current L2(A)	Max phase current L3(A)
0	–	–	–
2	–	8.7	–
4	–	8.7	8.7
6	8.7	8.7	8.7
9	8.7	15.6	15.6

3x400V, F1255-6

Max electrical addition (kW)	Max phase current L1(A)	Max phase current L2(A)	Max phase current L3(A)
0.0	–	–	–
0.5	2.2	–	–
1.0	–	4.3	–
1.5	2.2	4.3	–
2.0	–	–	8.7
2.5	2.2	–	8.7
3.0	–	4.3	8.7
3.5	2.2	4.3	8.7
4.0	7.5	4.3	7.5
4.5	9.7	4.3	7.5
5.0	7.5	–	16.2
5.5	9.7	–	16.2
6.0	7.5	4.3	16.2
6.5	9.7	4.3	16.2

3x230V, F1255-6

Max electrical addition (kW)	Max phase current L1(A)	Max phase current L2(A)	Max phase current L3(A)
0.0	–	–	–
0.5	–	2.2	2.2
1.0	–	4.3	4.3
1.5	–	6.5	6.5
2.0	–	8.6	8.6
2.5	–	10.8	10.8
3.0	8.7	4.3	11.5
3.5	8.7	6.5	13.2
4.0	8.7	8.6	15.0
4.5	8.7	10.8	16.9

3x230V, F1255-12

Max electrical addition (kW)	Max phase current L1(A)	Max phase current L2(A)	Max phase current L3(A)
0	–	–	–
2	–	8.7	8.7
4	8.7	8.7	15.1
6	15.1	15.1	15.1
9	15.1	27.1	27.1

1x230V, F1255-6

Max electrical addition (kW)	Max phase current L1(A)
0.0	–
0.5	2.2
1.0	4.3
1.5	6.5
2.0	8.6
2.5	10.8
3.0	13.0
3.5	15.2
4.0	17.3
4.5	19.5

1x230V, F1255-12

Max electrical addition (kW)	Max phase current L1(A)
0.0	–
1.0	4.3
2.0	8.7
3.0	13.0
4.0	17.4
5.0	21.7
6.0	26.1
7.0	30.4

If the current sensors are connected, the heat pump monitors the phase currents and allocates the electrical steps automatically to the least loaded phase.

Emergency mode

When the heat pump is set to emergency mode (SF1 is set to Δ) only the most necessary functions are activated.

- The compressor is off and heating is managed by the immersion heater.
- Hot water is not produced.
- The load monitor is not connected.

**NOTE**

The switch (SF1) must not be moved to "I" or " Δ " until F1255 has been filled with water. Components in the product can be damaged.

Power in emergency mode

The immersion heater's output in emergency mode is set with the dip-switch (S2) on the immersion heater board (AA1) according to the table below. The factory setting is 3.5 kW for F1255-6 and 6 kW for F1255-12 / -16.

3x400V (maximum electrical output, connected upon delivery 7 kW) for F1255-12 / -16) and 1x230V F1255-12

kW	1	2	3	4	5	6
1	off	off	off	off	off	on
2	off	off	on	off	off	off
3	off	off	on	off	off	on
4	off	off	on	off	on	off
5	on	off	on	off	off	on
6	on	off	on	off	on	off
7	on	off	on	off	on	on

3x400V (maximum electrical output, switched to 9 kW) for F1255 -12 / -16)

kW	1	2	3	4	5	6
2	off	off	off	off	on	off
4	off	off	on	off	on	off
6	on	off	on	off	on	off
9	on	off	on	on	on	on

3x400V for F1255-6

kW	1	2	3	4	5	6
0.5	on	off	off	off	off	off
1.0	off	off	on	off	off	off
1.5	on	off	on	off	off	off
2.0	off	off	off	off	on	off
2.5	on	off	off	off	on	off
3.0	off	off	on	off	on	off
3.5	on	off	on	off	on	off
4.0	off	on	on	off	off	on
4.5	on	on	on	off	off	on
5.0	off	on	off	off	on	on
5.5	on	on	off	off	on	on
6.0	off	on	on	off	on	on
6.5	on	on	on	off	on	on

3x230V for F1255-12

kW	1	2	3	4	5	6
2	off	off	off	on	off	off
4	off	on	off	on	off	off
6	on	on	off	on	off	off
9	on	on	on	on	off	off

3x230V for F1255-6

kW	1	2	3	4	5	6
0.5	off	on	off	off	off	off
1.0	off	off	off	on	off	off
1.5	off	on	off	on	off	off
2.0	on	off	off	off	off	off
2.5	on	on	off	off	off	off
3.0	on	off	off	on	off	off
3.5	on	on	off	on	off	off
4.0	on	off	off	on	on	off
4.5	on	on	off	on	on	off

1x230V for F1255-6

kW	1	2	3	4	5	6
0.5	on	off	off	off	off	off
1.0	off	off	on	off	off	off
1.5	on	off	on	off	off	off
2.0	off	off	off	off	on	on
2.5	on	off	off	off	on	off
3.0	off	off	on	off	on	off
3.5	on	off	on	off	on	off
4.0	off	off	on	off	on	on
4.5	on	off	on	off	on	on

1x230V and 3x400V for F1255-6 / -12 and 3x400V for F1255-12 / -16

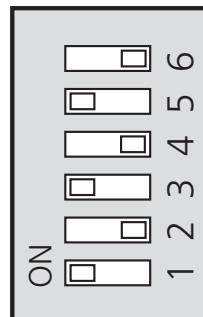

AA1-SF2

The image shows the dip-switch (AA1-SF2) in the factory setting, i.e. 3.5 kW for F1255-6 and 6 kW F1255-12 / -16 .

3x230V for F1255-6 and -12

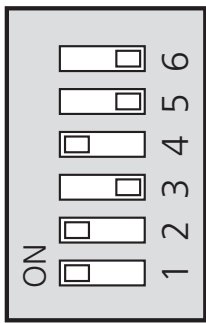

AA1-SF2

Only 3x230V, the image shows the dip-switch (AA1-SF2) in the factory setting, i.e. 3.5 kW for F1255-6 and 6 kW F1255-12.

Emergency mode thermostat

The supply temperature in emergency mode is set using a thermostat (FD1-BT30). It can be set to 35 (pre-set, for example under floor heating) or 45 °C (for example radiators).

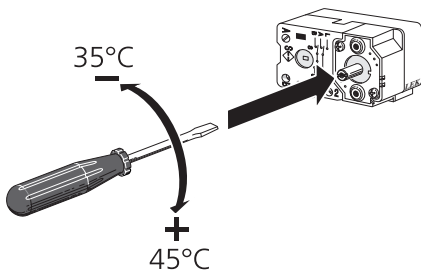

Optional connections

Load monitor

Integrated load monitor

F1255 is equipped with a simple form of integrated load monitor, which limits the power steps for the electric additional heat by calculating whether future power steps can be connected to the relevant phase without the specified main fuse being exceeded. In those cases where the current would exceed the specified main fuse, the power step is not permitted. The size of the property's main fuse is specified in menu 5.1.12.

Load monitor with current sensor

When many power-consuming products are connected in the property at the same time as the electric additional heat is in operation, there is a risk of the property's main fuses tripping. F1255 is equipped with a load monitor that, with the aid of current sensors, controls the power steps for the electric additional heat by redistributing the power between the different phases or disengaging the electric additional heat in event of an overload in a phase. If the overload remains despite the electric additional heat being disengaged, the compressor winds down. Reconnection occurs when other current consumption is reduced.

Connecting current sensors



NOTE

The building's phases can have different loads. If the inverter is connected to a heavily loaded phase, there is a risk of the compressor shutting down and the electrical addition operating longer than expected. This means that savings will not be as expected.

A current sensor should be installed on each incoming phase conductor in to the distribution box to measure the current. The distribution box is an appropriate installation point.

Connect the current sensors to a multi-core cable in an enclosure directly adjacent to the electrical distribution unit. The multi-core cable between the enclosure and F1255 must have a cable area of at least 0.5 mm².

Connect the cable to the input board (AA3) on terminal block X4:1-4 where X4:1 is the common terminal block for the three current sensors.

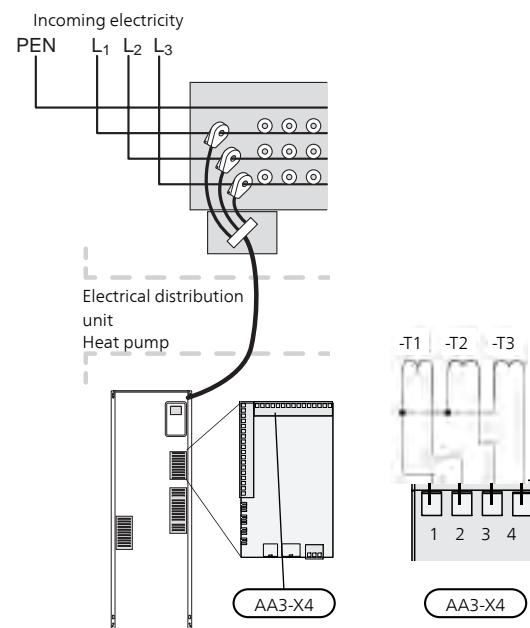

Uplink

Connect the network connected cable (straight, Cat.5e UTP) with RJ45-contact (male) to RJ45 contact (female) on the rear of the heat pump.

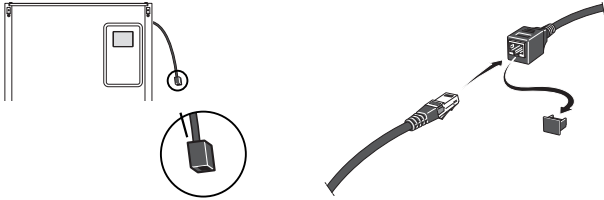

External connection options

F1255 has software-controlled AUX inputs/outputs on the input board (AA3), for connecting the external switch function or sensor. This means that, when an external switch function or sensor is connected to one of six special connections, the correct function must be selected for the correct connection in the software in F1255.



Caution

If an external switch function or sensor is connected to F1255, the function to use input or output must be selected in menu 5.4, see page 53.

Selectable inputs on the input board for these functions are:

AUX1	AA3-X6:9-10
AUX2	AA3-X6:11-12
AUX3	AA3-X6:13-14
AUX4	AA3-X6:15-16
AUX5	AA3-X6:17-18

Selectable output is AA3-X7.

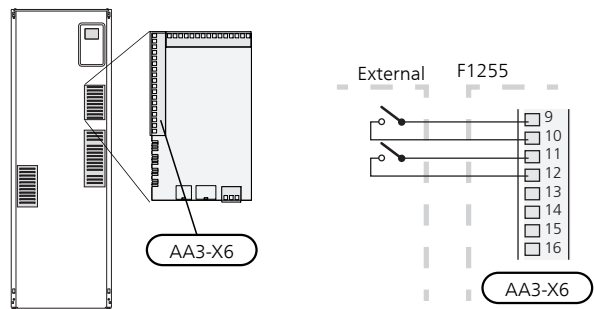
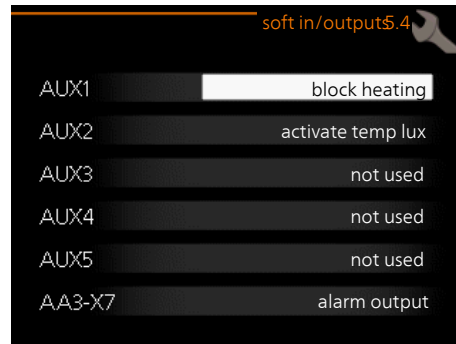

The example above uses the inputs AUX1 (X6:9-10) and AUX2 (X6:11-12) on the input circuit board (AA3).



Caution

Some of the following functions can also be activated and scheduled via menu settings.

Possible selection for AUX inputs



Caution

The external switch function or sensor is connected to terminal block X6 on the input board (AA3), which is positioned behind the front cover. The function for use input must be selected in menu 5.4.

Temperature sensor, cooling/heating

An extra temperature sensor (BT74) can be connected to F1255 in order to determine when it is time to switch between heating and cooling operation.

The temperature sensor is connected to the selected input (menu 5.4, the alternative is only displayed if cooling accessory is installed, see page 53) on terminal block X6 on the input card (AA3) which is located behind the front cover and is positioned in a suitable place in the climate system.

Use a 2 core cable of at least 0.5 mm² cable area.

Switch for external blocking of addition and/or compressor

Blocking for addition heat and compressor is connected on two different AUX inputs.

If external blocking of additional heat and/or compressor is wanted, this can be connected to terminal block X6 on the input board (AA3), which is positioned behind the front cover.

The additional heat and/or the compressor are disconnected by connecting a potential-free switch function to the input selected in menu 5.4, see page 53.

External blocking of addition and compressor can be combined.

A closed contact results in the electrical output being disconnected.

Contact for external tariff blocking

In those cases where external tariff blocking is used, it can be connected to terminal block X6 on the input board (AA3), which is positioned behind the front cover.

Tariff blocking means that the additional heat, the compressor, the heating and hot water are blocked by connecting a potential-free switch function to the input selected in menu 5.4, see page 53.

Closed switch means that tariff blocking is activated.



NOTE

When tariff blocking is activated, the min. supply line does not apply.

Switch for "SG ready"



NOTE

This function can only be used in mains networks that support the "SG Ready"-standard. "SG Ready" requires two AUX inputs.

In cases where this function is required, it must be connected to terminal block X6 on the input card (AA3).

"SG Ready" is a smart form of tariff control where your electricity supplier can affect the indoor, hot water and/or pool temperatures (if applicable) or simply block the additional heat and/or compressor in the heat pump at certain times of the day (can be selected in menu 4.1.5 after the function is activated). Activate the function by connecting potential-free switch functions to two inputs selected in menu 5.4 (SG Ready A and SG Ready B), see page 53.

Closed or open switch means one of the following:

■ Blocking (A: Closed, B: Open)

"SG Ready" is active. The compressor in the heat pump and additional heat is blocked like the day's tariff blocking.

■ Normal mode (A: Open, B: Open)

"SG Ready" is not active. No effect on the system.

■ Low price mode (A: Open, B: Closed)

"SG Ready" is active. The system focuses on costs savings and can for example exploit a low tariff from the electricity supplier or over-capacity from any own power source (effect on the system can be adjusted in the menu 4.1.5).

■ Overcapacity mode (A: Closed, B: Closed)

"SG Ready" is active. The system is permitted to run at full capacity at over capacity (very low price) with the electricity supplier (effect on the system is settable in menu 4.1.5).

(A = SG Ready A and B = SG Ready B)

Switch for +Adjust

Using +Adjust, the installation communicates with the underfloor heating's control centre* and adjusts the heat curve and calculated supply temperature according to the underfloor heating system's reconnection.

Activate the climate system you want +Adjust to affect by highlighting the function and pressing the OK button.

*Support for +Adjust required



NOTE

+Adjust must first be selected in menu 5.4 "soft inputs/outputs".

NOTE

Circuit board AA3 in the installation must have at least "Input version" 34 and the software version must have "display version 5539 or later for +Adjust to work. The version can be checked in menu 3.1 under "input version" respectively "display version". New software can be downloaded for free from www.nibeuplink.com.

NOTE

In systems with both under floor heating and radiators, NIBE ECS 40/41 should be used for optimum operation.

Contact for external blocking of heating

In those cases where external blocking of heat is used, it can be connected to terminal block X6 on the input board (AA3), which is positioned behind the front cover.

Heating operation is disconnected by connecting a potential-free switch function to the input selected in menu 5.4, see page 53.

A closed switch results in blocked heating operation.

NOTE

When heat blocking is activated, the min. supply line does not apply.

Switch for external blocking of hot water

In cases where external blocking of hot water is used, this can be connected to terminal block X6 on the input board (AA3), which is positioned behind the front cover.

Hot water operation is disconnected by connecting a potential-free switch function to the input selected in menu 5.4, see page 53.

A closed switch results in blocked hot water operation.

Switch for external forced control of brine pump

In those cases external forced control of brine pump is used, this can be connected to terminal block X6 on the input board (AA3), which is positioned behind the front cover.

The brine pump can be force controlled by connecting a potential free switch function to the input selected in menu 5.4, see page 53.

A closed switch means that the brine pump is active.

Contact for activation of "temporary lux"

An external switch function can be connected to F1255 for activation of the hot water function "temporary lux". The switch must be potential-free and connected to the selected input (menu 5.4, see page 53) on terminal block X6 on the input board (AA3).

"temporary lux" is activated for the time that the contact is connected.

Contact for activation of "economy"

An external switch function can be connected to F1255 to activate comfort mode "economy" for hot water operation. The switch must be potential-free and connected to the selected input (menu 5.4, see page 53) on terminal block X6 on the input board (AA3).

Comfort mode "economy" is activated for the time that the contact is connected.

Contact for activation of "external adjustment"

An external contact function can be connected to F1255 to change the supply temperature and the room temperature.

When the switch is closed the temperature changes in °C (if the room sensor is connected and activated). If a room sensor is not connected or activated, the desired change of "temperature" (heating curve offset) with the number of steps selected is set. The value is adjustable between -10 and +10.

■ climate system 1

The switch must be potential-free and connected to the selected input (menu 5.4, see page 53) on terminal block X6 on the input board (AA3).

The value for the change is set in menu 1.9.2, "external adjustment".

■ climate system 2 to 8

External adjustment for climate systems 2 to 8 requires accessories (ECS 40 or ECS 41).

See the accessory's installer handbook for installation instructions.

Contact for activation of fan speed



Caution

The external contact function functions only if the accessory FLM is installed and activated.

An external contact function can be connected to F1255 for activation of one of the four fan speeds. The switch must be potential free and connected to the selected input (menu 5.4, see page 53) on terminal block X6 on the input circuit board (AA3). When the switch closes, the selected fan speed is activated. Normal speed is resumed when the contact is opened again.

NV 10, pressure/level/flow monitor brine

If the level sensor (accessory NV10) is desired for the brine installation it can be connected on the selected input (menu 5.4, see page 53) on terminal block X6 on the input circuit board (AA3).

Pressure and flow sensors can also be connected to the input.

The input must be closed during normal operation.

Possible selection for AUX output (potential free variable relay)

It is possible to have an external connection through the relay function via a potential free variable relay (max 2 A) on the input circuit board (AA3), terminal block X7.

Optional functions for external connection:

- Indication of buzzer alarm.
- Controlling ground water pump.
- Cooling mode indication (only applies if cooling accessories are available).
- Control of circulation pump for hot water circulation.
- External circulation pump (for heating medium).
- External, reversing valve for hot water.
- Holiday indication.

If any of the above is installed to terminal block X7 it must be selected in menu 5.4, see page 53.

The common alarm is preselected at the factory.



NOTE

An accessory card is required if several functions are connected to terminal block X7 at the same time that the buzzer alarm is activated (see page 62).

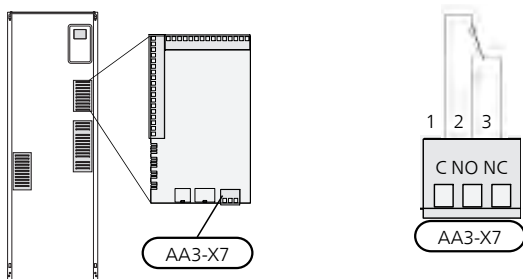

The picture shows the relay in the alarm position.

When switch (SF1) is in the "⏻" or "⚠" position the relay is in the alarm position.

External circulation pump, ground water pump or hot water circulation pump connected to the buzzer alarm relay as illustrated below.



NOTE

Mark up any junction boxes with warnings for external voltage.

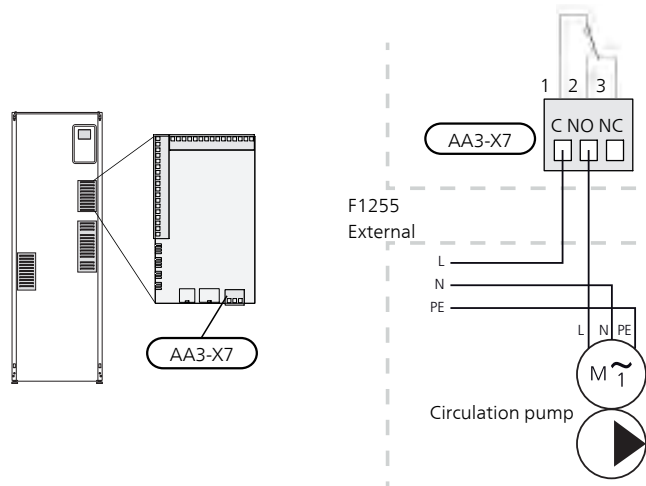

Caution

The relay outputs can have a max load of 2 A (230V ~).

Connecting accessories

Instructions for connecting accessories are in the installation instructions provided for the respective accessory. See information at nibe.eu for the list of the accessories that can be used with F1255.

Accessories with circuit board AA5

Accessories that contain circuit board AA5 are connected to the heat pump terminal block AA3-X4: 13-15. Use cable type LiYY, EKKX or similar.

If several accessories are to be connected, connect the first accessory card directly to the heat pump terminal block. Other accessory boards are connected to the first in series.

Because there can be different connections for accessories with circuit boards AA5, you should always read the instructions in the manual for the accessory that you are going to install.

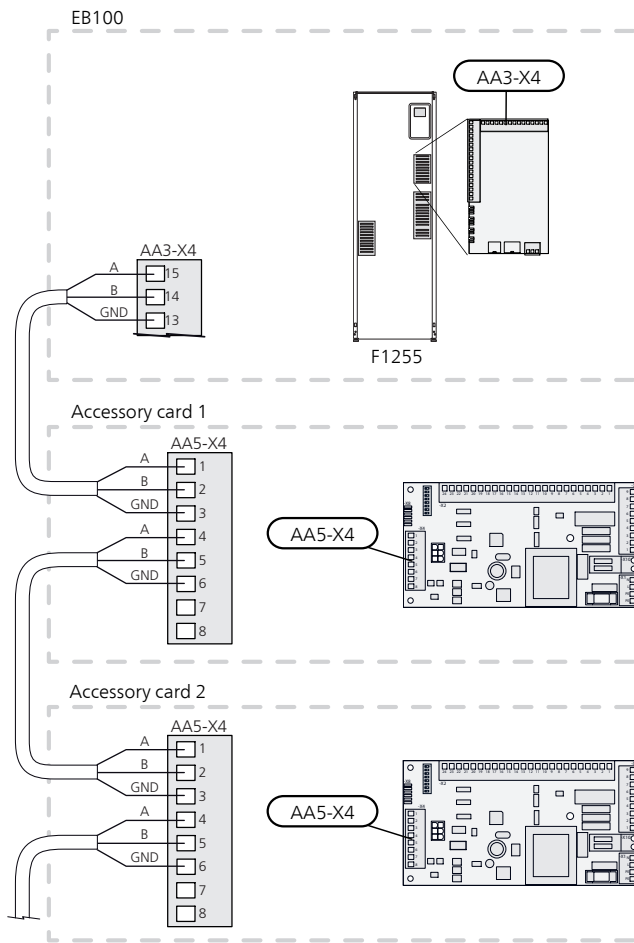

Accessories with circuit board AA9

Accessories that contain the circuit board AA9 are connected to the heat pump's terminal block X4:9-12 on the input board AA3. Use cable type LiYY, EKKX or equivalent.

Because there can be different connections for accessories with circuit boards AA9, you should always read the instructions in the manual for the accessory that you are going to install.

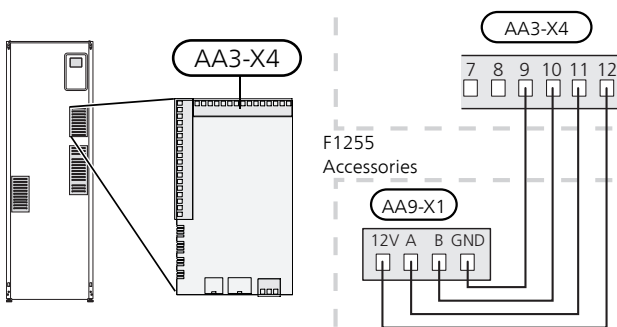

6 Commissioning and adjusting

Preparations

1. Ensure that F1255 has not been damaged during transport.
2. Check that the switch (SF1) is in position "⏻".
3. Check for water in the hot water heater and climate system.



Caution

Check the miniature circuit-breaker and the motor protection breakers. They may have tripped during transportation.



NOTE

Do not start F1255 if there is a risk that the water in the system has frozen.

Filling and venting



Caution

Insufficient venting can damage internal components in F1255.

Filling and venting the climate system

Filling

1. Open the filling valve (external, not included with the product). Fill the coil in the hot water heater and the rest of the climate system with water.
2. Open the venting valve (QM22).
3. When the water that exits the venting valve (QM22) is not mixed with air, close the valve. After a while the pressure starts to rise.
4. Close the filling valve when the correct pressure is obtained.

Venting

1. Bleed the heat pump via a vent valve (QM22) and the rest of the climate system via their relevant vent valves.
2. Keep topping up and venting until all air has been removed and the pressure is correct.



NOTE

The pipe from the coil in the container must be drained of water before air can be released. This means that the system is not necessarily bled despite the flow of water when the vent valve (QM22) is opened.

Filling the hot water heater

1. Open a hot water tap in the house.
2. Fill the hot water heater through the cold water connection (XL3).

3. When the water that comes out of the hot water tap is no longer mixed with air, the water heater is full and the tap can be closed.

Filling and venting the brine system

When filling the brine system, mix the water with anti-freeze in an open container. The mixture should be protected against freezing down to about -15°C. The brine is topped up by connecting a filling pump.

1. Check the brine system for leakage.
2. Connect the filling pump and return line on the brine system's filling connection (QZ20) (accessory).
3. If alternative 1 (level vessel) is used, close the valve under the level vessel (CM2).
4. Close the reversing valve in the filling connection (QZ20).
5. Open the valves on the filling connection (QZ20).
6. Start the filling pump.
7. Fill until liquid enters the return pipe.
8. Close the valves on the filling connection (QZ20).
9. Open the reversing valve in the filling connection (QZ20).
10. If alternative 1 (level vessel) is used, open the valve under the level vessel (CM2).

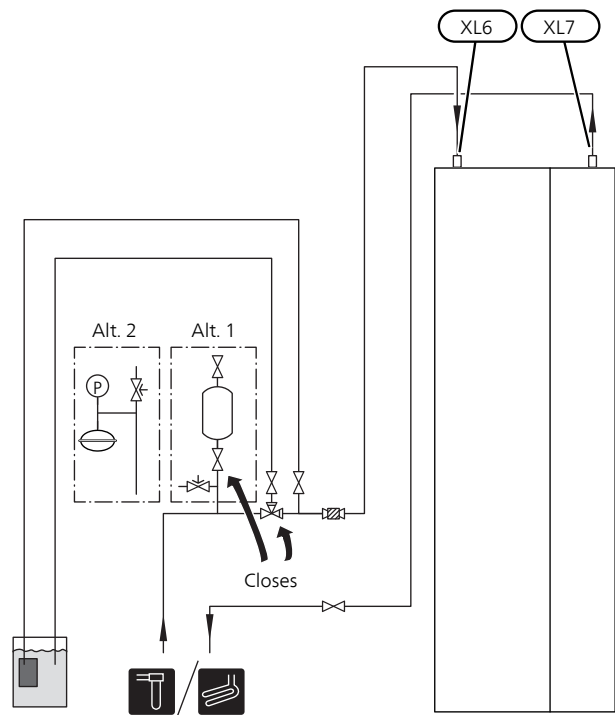

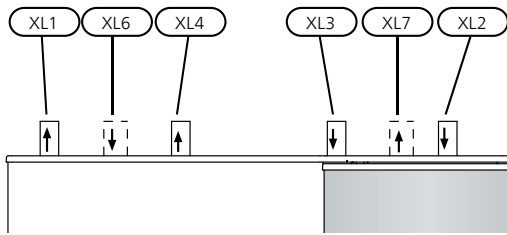

- XL1 Connection, heating medium flow
- XL2 Connection, heating medium return
- XL3 Connection, cold water
- XL4 Connection, hot water
- XL6 Connection, brine in
- XL7 Connection, brine out

Symbol key

Symbol	Meaning
	Shut-off valve
	Shunt / shuttle valve
	Safety valve
	Pressure gauge
	Filterball (ball valve with integrated particle filter)
	Expansion vessel
	Level vessel

Start guide



NOTE

There must be water in the climate system before the switch is set to "I".

1. Set switch (SF1) on F1255 to position "I".
2. Follow the instructions in the display's start guide. If the start guide does not start when you start the F1255, start it manually in menu 5.7.



TIP

See page 38 for a more in-depth introduction to the heat pump's control system (operation, menus etc.).

If the building is cooled when F1255 starts, the compressor may not be able to meet the entire demand without having to use additional heating.

Commissioning

The first time the heat pump is started a start guide is started. The start guide instructions state what needs to be carried out at the first start together with a run through of the heat pump's basic settings.

The start guide ensures that start-up is carried out correctly and cannot be bypassed. The start guide can be started later in menu 5.7.



Caution

As long as the start guide is active, no function in the installation will start automatically.

The guide will appear at each installation re-start until it is deselected on the last page.

Operation in the start guide

A. Page

B. Name and menu number

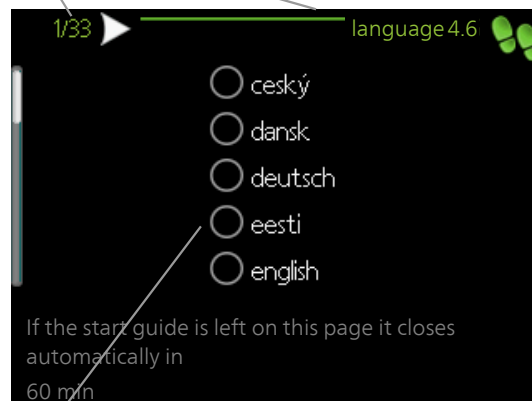

C. Option / setting

A. Page

Here you can see how far you have come in the start guide.

Scroll between the pages of the start guide as follows:

1. Turn the control knob until one of the arrows in the top left corner (at the page number) has been marked.
2. Press the OK button to skip between the pages in the start guide.

B. Name and menu number

Read what menu in the control system this page of the start guide is based on. The digits in brackets refer to the menu number in the control system.

If you want to read more about affected menus either consult the help menu or read the user manual.

C. Option / setting

Make settings for the system here.

D. Help menu



In many menus there is a symbol that indicates that extra help is available.

To access the help text:

1. Use the control knob to select the help symbol.
2. Press the OK button.

The help text often consists of several windows that you can scroll between using the control knob.

Post adjustment and venting

Pump adjustment, automatic operation

Brine side

The brine pump must run at the correct speed for the correct flow in the brine system. F1255 has a brine pump that can be automatically controlled in standard mode. Certain functions and accessories may require that they are run manually and the correct speed must then be set, see section Pump adjustment, manual operation.

The automatic control occurs when the compressor is running and it sets the speed of the brine pump to obtain the optimal temperature difference between the supply and return lines. For passive cooling operation, for example, the brine pump must run at a set speed, which is set in menu 5.1.9

Heating medium side

The heating medium pump must run at the correct speed for the correct flow in the heating medium system, F1255 has a heating medium pump that can be automatically controlled in standard mode. Certain functions and accessories may require that they are run manually and the correct speed must then be set, see section Pump adjustment, manual operation.

This automatic control occurs when the compressor is running and sets the speed of the heating medium pump, for the present operating mode, to obtain the optimal temperature difference between the supply and return lines. During heating operation, the set DOT (dimensioned outdoor temperature) and temperature differential in menu 5.1.14 are used. If necessary, the maximum speed of the circulation pump can be limited in menu 5.1.11.

Pump adjustment, manual operation

Brine side

F1255 has a brine pump that is automatically controlled. If a manual speed is required, open menu 5.1.9 (see page 46) and deactivate "auto" and set the pump's speed according to the diagram below.



Caution

When an accessory for passive cooling is used, the brine pump speed must be set in menu 5.1.9.

— Available pressure, kPa
—_p Electrical output, W

F1255 6 kW

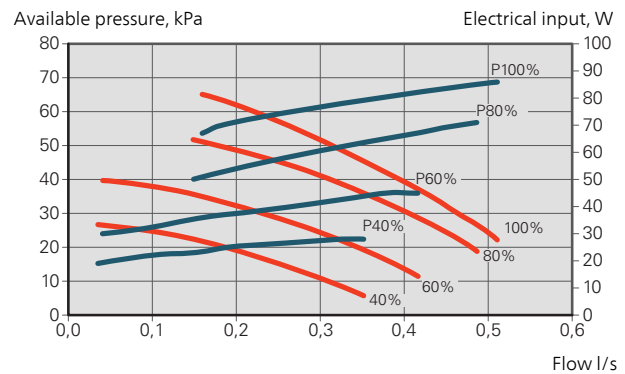

F1255 12 kW

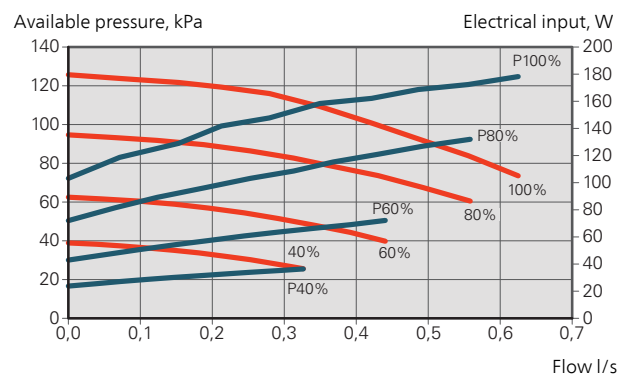

F1255 16 kW

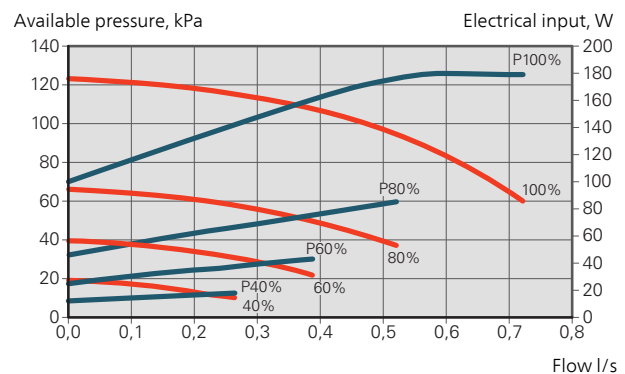

Heating medium side

F1255 has a heating medium pump that is automatically controlled. If a manual speed is required, open menu 5.1.11 (see page 47) and deactivate "auto" and set the pump's speed according to the diagram below.

— Available pressure, kPa
 —_p Electrical output, W

F1255 6 kW

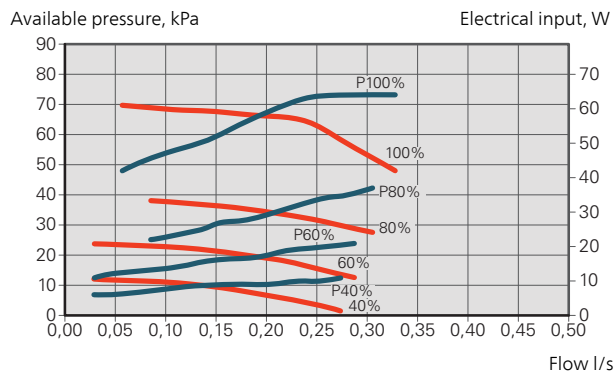

F1255 12 kW

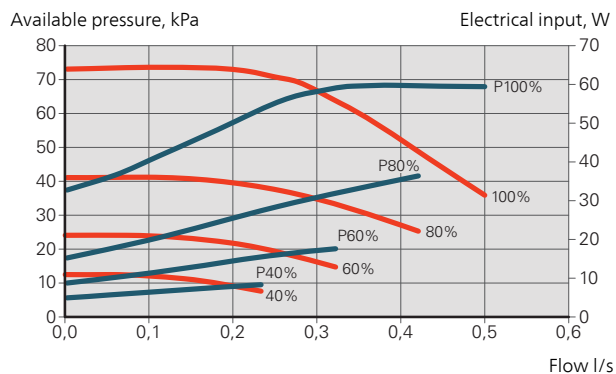

F1255 16 kW

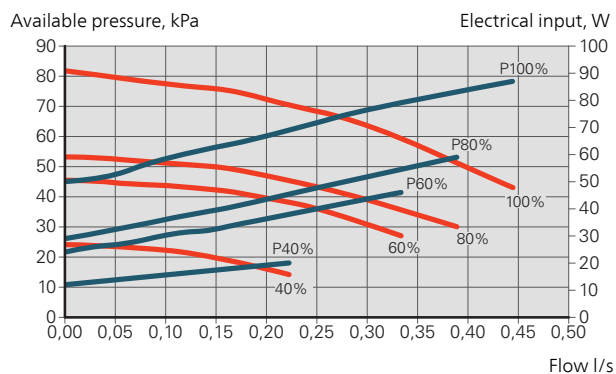

Readjusting, venting, heat medium side

Air is initially released from the hot water and venting may be necessary. If gurgling sounds can be heard from the heat pump or climate system, the entire system will require additional venting.

Readjusting, venting, collector side

Level vessel

Check the fluid level in the level vessel (CM2). If the fluid level has dropped, top up the system.

1. Close the valve under the vessel.
2. Disconnect the connection on top of the vessel.
3. Fill with brine until approx 2/3 of the vessel is full.
4. Reconnect the connector at the top of the vessel.
5. Open the valve under the vessel.

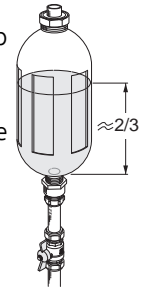

If the pressure in the system needs to be raised, this is done by closing the valve on the outgoing main line when the brine pump (GP2) is in operation and the level vessel (CM2) is open, so that liquid is drawn down from the vessel.

Expansion vessel

If a pressure expansion vessel (CM3) is used instead of a level vessel, the pressure level is checked. If the pressure drops, the system should be replenished.

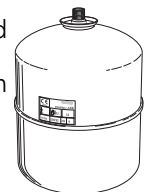

Post adjusting the room temperature

If the required room temperature is not obtained, readjustment may be necessary.

Cold weather conditions

- When the room temperature is too low, increase "heating curve" in menu 1.9.1.1 by one increment.
- When the room temperature is too high, reduce "heating curve" in menu 1.9.1.1 by one increment.

Warm weather conditions

- When the room temperature is too low, increase "temperature" (offset heating curve) in menu 1.1.1 by one increment.
- When the room temperature is too high, reduce "temperature" (offset heating curve) in menu 1.1.1 by one increment.

Setting the cooling/heating curve

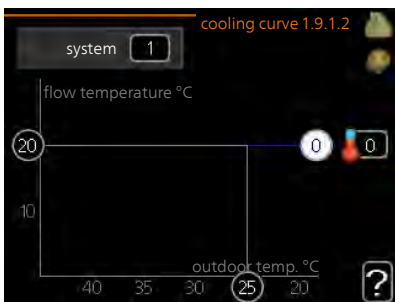
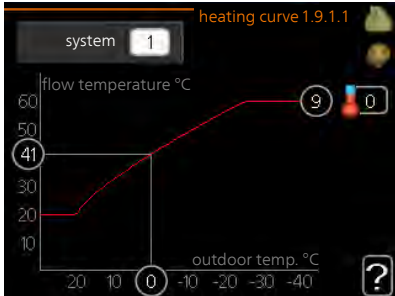

heating curve

Setting range: 0 – 15

Default value: 9

cooling curve (accessory required)

Setting range: 0 – 9

Default value: 0

You can select heating or cooling in the **curve** menu. The next menu (heating curve/cooling curve) shows the heating and cooling curves for your house. The task of the curve is to give an even indoor temperature, regardless of the outdoor temperature, and thereby energy efficient operation. It is from these heat curves that the heat pump's control computer determines the temperature of the water to the system, the supply temperature, and therefore the indoor temperature. Select the curve and read off how the supply temperature changes at different outdoor temperatures here. The number to the far right of "system" displays which system you have selected the heating curve/cooling curve for.

Curve coefficient

The slopes of the heating /cooling curves indicate how many degrees the supply temperature is to be increased/reduced when the outdoor temperature drops/increases. A steeper slope means a higher supply temperature for heating or a lower supply temperature for cooling at a certain outdoor temperature.

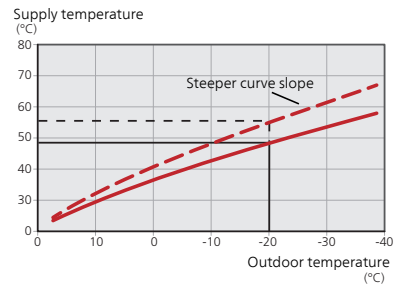

The optimum slope depends on the climate conditions in your location, if the house has radiators or under floor heating and how well insulated the house is.

The curve is set when the heating installation is installed, but may need adjusting later. Normally, the curve will not need further adjustment.



Caution

When making fine adjustments of the indoor temperature, the curve must be offset up or down instead, this is done in menu 1.1 **temperature**.

Curve offset

An offset of the curve means that the supply temperature changes by the same amount for all the outdoor temperatures, e.g. that a curve offset of +2 steps increases the supply temperature by 5 °C at all outdoor temperatures.

Flow line temperature– maximum and minimum values

Because the flow line temperature cannot be calculated higher than the set maximum value or lower than the set minimum value the heating curve flattens out at these temperatures.



Caution

Under floor heating systems are normally **max flow line temperature** set to between 35 and 45 °C.

Must be restricted with underfloor cooling min. flow line temp. to prevent condensation.

Check the max temperature for your floor with your installer/floor supplier.

The figure at the end of the curve indicates the curve slope. The figure beside the thermometer gives the curve offset. Use the control knob to set a new value. Confirm the new setting by pressing the OK button.

Curve 0 is an own curve created in menu 1.9.7.

To select another curve (slope):



NOTE

If you only have one climate system, the number of the curve is already marked when the menu window opens.

1. Select the climate system (if more than one) for which the curve is to be changed.

2. When the climate system selection has been confirmed, the curve number is marked.
3. Press the OK button to access the setting mode
4. Select a new curve. The curves are numbered from 0 to 15, the greater the number, the steeper the slope and the greater the supply temperature. Curve 0 means that **own curve** (menu 1.9.7) is used.
5. Press the OK button to exit the setting.

To read off a curve:

1. Turn the control knob so that the ring on the shaft with the outdoor temperature is marked.
2. Press the OK button.
3. Follow the grey line up to the curve and out to the left to read off the value for the supply temperature at the selected outdoor temperature.
4. You can now select to take read outs for different outdoor temperatures by turning the control knob to the right or left and read off the corresponding flow temperature.
5. Press the OK or Back button to exit read off mode.



TIP

Wait 24 hours before making a new setting, so that the room temperature has time to stabilise.

If it is cold outdoors and the room temperature is too low, increase the curve slope by one increment.

If it is cold outdoors and the room temperature is too high, lower the curve slope by one increment.

If it is warm outdoors and the room temperature is too low, increase the curve offset by one increment.

If it is warm outdoors and the room temperature is too high, lower the curve offset by one increment.

7 Control - Introduction

Display unit

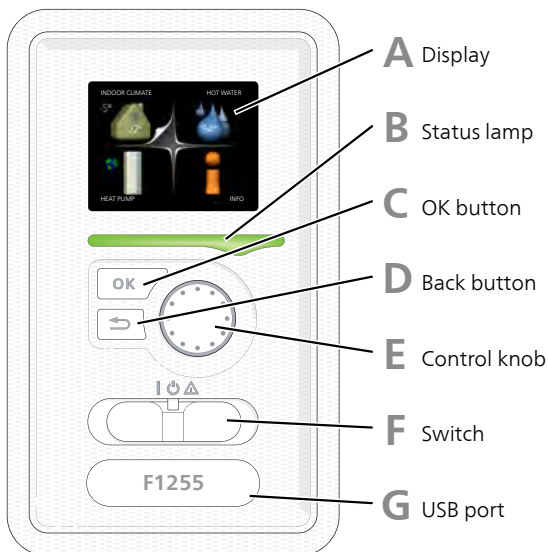

A Display

Instructions, settings and operational information are shown on the display. You can easily navigate between the different menus and options to set the comfort or obtain the information you require.

B Status lamp

The status lamp indicates the status of the heat pump. It:

- lights green during normal operation.
- lights yellow in emergency mode.
- lights red in the event of a deployed alarm.

C OK button

The OK button is used to:

- confirm selections of sub menus/options/set values/page in the start guide.

D Back button

The back button is used to:

- go back to the previous menu.
- change a setting that has not been confirmed.

E Control knob

The control knob can be turned to the right or left. You can:

- scroll in menus and between options.
- increase and decrease the values.
- change page in multiple page instructions (for example help text and service info).

F Switch (SF1)

The switch assumes three positions:

- On (I)
- Standby (⏻)
- Emergency mode (⚠)

Emergency mode must only be used in the event of a fault on the heat pump. In this mode, the compressor switches off and the immersion heater engages. The heat pump display is not illuminated and the status lamp illuminates yellow.

G USB port

The USB port is hidden beneath the plastic badge with the product name on it.

The USB port is used to update the software.

Visit <http://www.nibeuplink.com> and click the "Software" tab to download the latest software for your installation.

Menu system

When the door to the heat pump is opened, the menu system's four main menus are shown in the display as well as certain basic information.

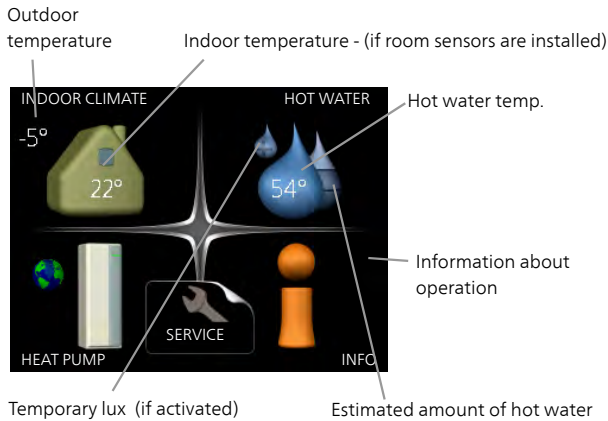

Menu 1 - INDOOR CLIMATE

Setting and scheduling the indoor climate. See information in the help menu or user manual.

Menu 2 - HOT WATER

Setting and scheduling hot water production. See information in the help menu or user manual.

Menu 3 - INFO

Display of temperature and other operating information and access to the alarm log. See information in the help menu or user manual.

Menu 4 - HEAT PUMP

Setting time, date, language, display, operating mode etc. See information in the help menu or user manual.

Menu 5 - SERVICE

Advanced settings. These settings are only intended for installers or service engineers. The menu is visible when the Back button is pressed for 7 seconds, when you are in the start menu. See page 44.

Symbols in the display

The following symbols can appear in the display during operation.

Symbol	Description
	This symbol appears by the information sign if there is information in menu 3.1 that you should note.
	These two symbols indicate whether the compressor or addition is blocked in F1255. These can, for example, be blocked depending on which operating mode is selected in menu 4.2, if blocking is scheduled in menu 4.9.5 or if an alarm has occurred that blocks one of them. Blocking the compressor. Blocking additional heat.
	This symbol appears if periodic increase or lux mode for the hot water is activated.
	This symbol indicates whether "holiday setting" is active in 4.7.
	This symbol indicates whether F1255 has contact with Uplink.
	This symbol indicates the actual speed of the fan if the speed has changed from the normal setting. Accessory NIBE FLM is needed.
	This symbol indicates whether pool heating is active. Accessory needed.
	This symbol indicates whether cooling is active. Accessory needed.

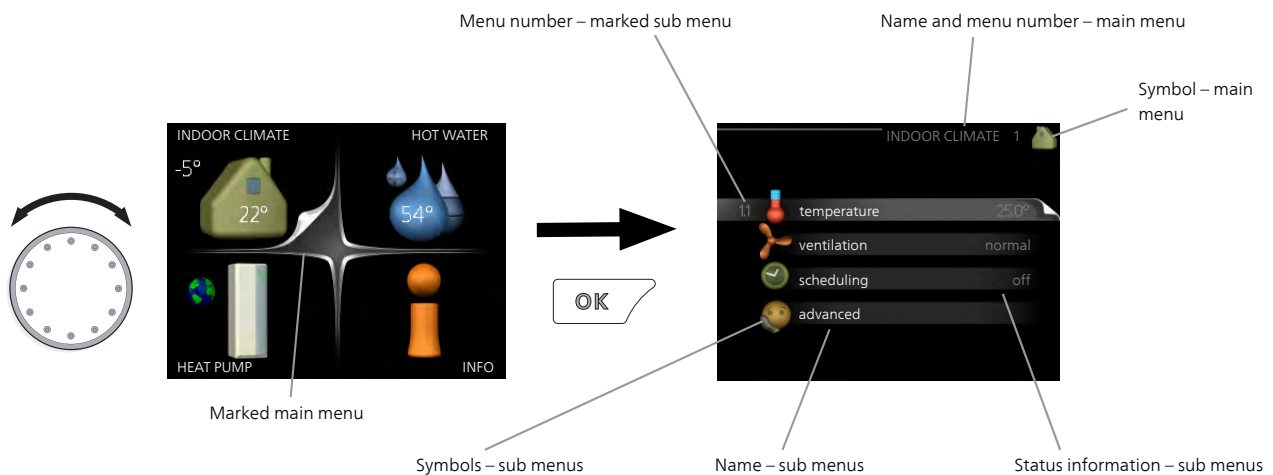

Operation

To move the cursor, turn the control knob to the left or the right. The marked position is white and/or has a turned up tab.



Selecting menu

To advance in the menu system select a main menu by marking it and then pressing the OK button. A new window then opens with sub menus.

Select one of the sub menus by marking it and then pressing the OK button.



Selecting options



In an options menu the current selected option is indicated by a green tick.



To select another option:





1. Mark the applicable option. One of the options is pre-selected (white). 
2. Press the OK button to confirm the selected option. The selected option has a green tick. 

Setting a value



Values to be changed

To set a value:

1. Mark the value you want to set using the control knob. 
2. Press the OK button. The background of the value becomes green, which means that you have accessed the setting mode. 
3. Turn the control knob to the right to increase the value and to the left to reduce the value. 
4. Press the OK button to confirm the value you have set. To change and return to the original value, press the Back button. 

Use the virtual keyboard

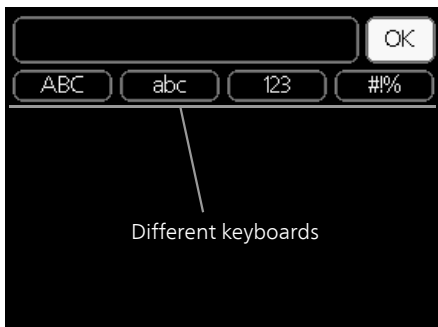

In some menus where text may require entering, a virtual keyboard is available.

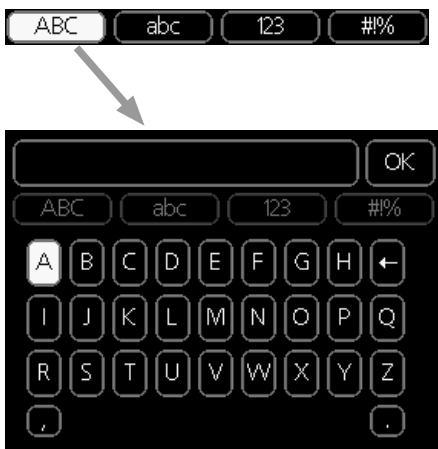

Depending on the menu, you can gain access to different character sets which you can select using the control knob. To change character table, press the Back button. If a menu only has one character set the keyboard is displayed directly.

When you have finished writing, mark "OK" and press the OK button.

Scroll through the windows

A menu can consist of several windows. Turn the control knob to scroll between the windows.



Current menu window Number of windows in the menu

Scroll through the windows in the start guide



Arrows to scroll through window in start guide

1. Turn the control knob until one of the arrows in the top left corner (at the page number) has been marked.
2. Press the OK button to skip between the steps in the start guide.

Help menu



In many menus there is a symbol that indicates that extra help is available.

To access the help text:

1. Use the control knob to select the help symbol.
2. Press the OK button.

The help text often consists of several windows that you can scroll between using the control knob.

8 Control - Menus

Menu 1 - INDOOR CLIMATE

1 - INDOOR CLIMATE	1.1 - temperature	1.1.1 - heating			
		1.1.2 - cooling *			
	1.2 - ventilation *				
	1.3 - scheduling	1.3.1 - heating			
		1.3.2 - cooling *			
		1.3.3 - ventilation *			
	1.9 - advanced	1.9.1 - curve	1.9.1.1 heating curve		
			1.9.1.2 - cooling curve *		
		1.9.2 - external adjustment			
		1.9.3 - min. flow line temp.	1.9.3.1 - heating		
			1.9.3.2 - cooling *		
		1.9.4 - room sensor settings			
		1.9.5 - cooling settings *			
		1.9.6 - fan return time *			
		1.9.7 - own curve	1.9.7.1 - heating		
1.9.7.2 - cooling *					
1.9.8 - point offset					
1.9.9 - night cooling					
1.9.11 - +Adjust					
1.9.12 - FLM cooling*					

Menu 2 - HOT WATER

2 - HOT WATER	2.1 - temporary lux			
	2.2 - comfort mode			
	2.3 - scheduling			
	2.9 - advanced	2.9.1 - periodic increase		
		2.9.2 - hot water recirc.		

Menu 3 - INFO

3 - INFO	3.1 - service info	
	3.2 - compressor info	
	3.3 - add. heat info	
	3.4 - alarm log	
	3.5 - indoor temp. log	

* Accessories are needed.

Menu 4 - HEAT PUMP

4 - HEAT PUMP	4.1 - plus functions	4.1.1 - pool *
		4.1.3 - internet
		4.1.3.1 - Uplink
		4.1.3.8 - tcp/ip settings
		4.1.3.9 - proxy settings
		4.1.4 - sms *
		4.1.5 - SG Ready
		4.1.6 - smart price adaption™
		4.1.7 - smart home
		4.1.8 - smart energy source™
		4.1.8.1 - settings
		4.1.8.2 - set. price
		4.1.8.3 - CO2 impact
		4.1.8.4 - tariff periods, electricity
		4.1.8.5 - tariff periods, fixed price
		4.1.8.6 - tariff per, ext. shunt add
		4.1.8.7 - tariff per, ext. step add
		4.1.8.8 - tariff periods, OPT10
		Menu 4.1.10 – solar electricity *
	4.2 - op. mode	
	4.3 - my icons	
	4.4 - time & date	
	4.6 - language	
	4.7 - holiday setting	
	4.9 - advanced	4.9.1 - op. prioritisation
		4.9.2 - auto mode setting
		4.9.3 - degree minute setting
		4.9.4 - factory setting user
		4.9.5 - schedule blocking

* Accessory needed.

Menu 5 - SERVICE

Overview

5 - SERVICE	5.1 - operating settings	5.1.1 - hot water settings
		5.1.2 - max flow line temperature
		5.1.3 - max diff flow line temp.
		5.1.4 - alarm actions
		5.1.5 - fan sp. exhaust air *
		5.1.7 - br pmp al set.
		5.1.8 - operating mode brine pump
		5.1.9 - brine pump speed
		5.1.10 - op. mod heat med pump
		5.1.11 - pump speed heating medium
		5.1.12 - internal electrical addition
		5.1.14 - flow set. climate system
		5.1.22 - heat pump testing
		5.1.24 - blockFreq
	5.2 - system settings	
	5.3 - accessory settings	5.3.1 - FLM *
		5.3.2 - shunt controlled add. heat *
		5.3.3 - extra climate system *
		5.3.4 - solar heating *
		5.3.6 - step controlled add. heat
		5.3.8 - hot water comfort *
		5.3.11 - modbus *
		5.3.12 - exhaust/supply air module *
		5.3.15 - GBM communications module *
		5.3.16 - humidity sensor *
		5.3.21 - external energy meter*
	5.4 - soft in/outputs	
	5.5 - factory setting service	
	5.6 - forced control	
	5.7 - start guide	
	5.8 - quick start	
	5.9 - floor drying function	
	5.10 - change log	

* Accessory needed.

Go to the main menu and hold the Back button in for 7 seconds to access the Service menu.

Sub-menus

Menu **SERVICE** has orange text and is intended for the advanced user. This menu has several sub-menus. Status information for the relevant menu can be found on the display to the right of the menus.

operating settings Operating settings for the heat pump.

system settings System settings for the heat pump, activating accessories etc.

accessory settings Operational settings for different accessories.

soft in/outputs Setting software controlled in and outputs on the input circuit board (AA3).

factory setting service Total reset of all settings (including settings available to the user) to default values.

forced control Forced control of the different components in the heat pump.

start guide Manual start of the start guide which is run the first time the heat pump is started.

quick start Quick starting the compressor.



NOTE

Incorrect settings in the service menus can damage the heat pump.

Menu 5.1 - operating settings

Operating settings can be made for the heat pump in the sub menus.

Menu 5.1.1 - hot water settings

start temp. economy / normal / lux

Setting range: 5 – 70 °C

Factory setting (°C):

	eco- nomy	normal	luxury
Enamel	40	44	47
Copper	43	47	50
Stainless	40	44	47

stop temp. economy / normal / lux

Setting range: 5 – 70 °C

Factory setting (°C):

	eco- nomy	normal	luxury
Enamel	44	48	51
Copper	47	51	54
Stainless	44	48	51

stop temp. per. increase

Setting range: 55 – 70 °C

Factory setting: 55 °C

high power

Setting range: on/off

Factory setting: off

Here you set the start and stop temperature of the hot water for the different comfort options in menu 2.2 as well as the stop temperature for periodic increase in menu 2.9.1.

For a higher charge output click the high output selection.

With "high power" activated, the hot water is charged with greater power than standard mode and therefore has a faster recharging time.

Menu 5.1.2 - max flow line temperature

climate system

Setting range: 20-80 °C

Default value: 60 °C

Set the maximum supply temperature for the climate system here. If the installation has more than one climate system, individual maximum supply temperatures can be set for each system. Climate systems 2 - 8 cannot be set to a higher max supply temperature than climate system 1.



Caution

Underfloor heating systems are normally **max flow line temperature** set between 35 and 45 °C.

Check the max floor temperature with your floor supplier.

Menu 5.1.3 - max diff flow line temp.

max diff compressor

Setting range: 1 – 25 °C

Default value: 10 °C

max diff addition

Setting range: 1 – 24 °C

Default value: 3 °C

Here you set the maximum permitted difference between the calculated and actual supply temperature during compressor respectively add. heat mode. Max diff. additional heat can never exceed max diff. compressor

max diff compressor

If the current supply temperature **exceeds** the calculated flow with set value, the degree minute value is set to 0. The compressor in the heat pump stops when there is only a heating demand.

max diff addition

If "addition" is selected and activated in menu 4.2 and the present supply temp **exceeds** the calculated with set value, the additional heat is forced to stop.

Menu 5.1.4 - alarm actions

Select how you want the heat pump to alert you that there is an alarm in the display here.

The different alternatives are that the heat pump stops producing hot water (default setting) and/or reduces the room temperature.



Caution

If no alarm action is selected, it can result in higher energy consumption in the event of an alarm.

Menu 5.1.5 - fan sp. exhaust air (accessory is required)

normal and speed 1-4

Setting range: 0 – 100 %

Set the speed for the five different selectable speeds for the fan here.



Caution

An incorrectly set ventilation flow can damage the house and may also increase energy consumption.

Menu 5.1.7 - br pmp al set.

min. brine out

Setting range: -12 – 15 °C

Default value: -8 °C

min. brine out

Set the temperature at which the heat pump is to activate the alarm for low temperature in outgoing brine.

If "automatic reset" is selected, the alarm resets when the temperature has increased by 1 °C below the set value.

The compressor winds down when the brine temperature reaches the set minimum value for brine temperature. Compressor control attempts to maintain the brine at a temperature 2 ° greater than the set value for brine out.

Menu 5.1.8 - operating mode brine pump

op. mode

Setting range: intermittent, continuous, 10 days continuous

Default value: intermittent

Set the operating mode of the brine pump here.

intermittent: The brine pump starts approx. 20 seconds before and stops approx. 20 seconds after the compressor.

continuous: Continuous operation.

10 days continuous: Continuous operation for 10 days. Then the pump shifts to intermittent operation.



TIP

You can use "10 days continuous" at start-up to obtain continuous circulation during a start-up time in order to make it easier to bleed the system.

Menu 5.1.9 - brine pump speed

op. mode

Setting range: auto / manual / fixed delta

Default value: auto

delta T

Setting range: 2 - 10 °C

Factory setting: 4 °C

speed in wait mode

Setting range: 1 - 100 %

Factory setting: 70 %

manual

Setting range: 1 - 100 %

Factory setting: 100 %

speed active cooling (accessory is required)

Setting range: 1 - 100 %

Factory setting: 70 %

speed passive cooling (accessory is required)

Setting range: 1 - 100 %

Factory setting: 100 %

Set the speed of the brine pump here. Select "auto" if the speed of the brine pump is to be regulated automatically (factory setting) for optimal operation.

For manual operation of the brine pump deactivate "auto" and set the value to between 1 and 100%.

For operation of brine pump with "fixed delta", select "fixed delta" under "op. mode" and set the value between 2 and 10 °C.

If there are accessories for cooling present or if the heat pump has a built-in function for cooling you can also set the brine pump speed during passive cooling operation (the brine pump then runs in manual operation).

If the continuous operating mode (see "Menu 5.1.8 - operating mode brine pump", page 46) has been selected one can also choose waiting mode. The circulation pump continues to run while the compressor stops.

Menu 5.1.10 - op. mod heat med pump

op. mode

Setting range: auto, intermittent

Default value: auto

Set the operating mode of the heating medium pump here.

auto: The heating medium pump runs according to the current operating mode for F1255.

intermittent: The heating medium pump starts approx. 20 seconds before and stops at the same time as the compressor.

Menu 5.1.11 - pump speed heating medium

Operating status

Setting range: auto / manual

Default value: auto

Manual setting, hot water

Setting range: 1 - 100 %

Default values: 70 %

Manual setting, heating

Setting range: 1 - 100 %

Default values: 70 %

Manual setting, pool

Setting range: 1 - 100 %

Default values: 70 %

wait mode

Setting range: 1 - 100 %

Default values: 30 %

max. allowed speed

Setting range: 50 - 100 %

Default values: 100 %

speed active cooling (accessory is required)

Setting range: 1 - 100 %

Default values: 70 %

speed passive cooling (accessory is required)

Setting range: 1 - 100 %

Default values: 70 %

Set the speed at which the heating medium pump is to operate in the present operating mode. Select "auto" if the speed of the heating medium pump is to be regulated automatically (factory setting) for optimal operation.

If "auto" is activated for heating operation, you can also make the setting "max. allowed speed" which restricts the heating medium pump and does not allow it to run at a higher speed than the set value.

For manual operation of the heating medium pump, deactivate "auto" for the current operating mode and set the value to between 0 and 100% (the previously set value for "max. allowed speed" no longer applies).

"**heating**" means operating mode heating for the heating medium pump.

"**wait mode**" means heating or cooling operating modes for the heating medium pump but when the heat pump has neither a need for compressor operation nor electrical addition and slows down.

"**hot water**" means operating mode hot water for the heating medium pump.

"**pool**" (accessory required) means operating mode pool heating for the heating medium pump.

"**cooling**" (accessory required) means operating mode cooling for the heating medium pump.

If there are accessories for cooling present or if the heat pump has a built-in function for cooling you can also set the heating medium pump speed during active respectively cooling operating modes (the heating medium pump then runs in manual operation).

Menu 5.1.12 - internal electrical addition

max connected el. add. 3x400V, F1255-12 / -16

Setting range F1255-12 / -16: 7 / 9 kW

Factory setting F1255-12 / -16: 7 kW

set max electrical add.

Setting range F1255-6 1x230V: 0 - 4.5 kW

Setting range F1255-6 3x230V: 0 - 4.5 kW

Setting range F1255-12 1x230V: 0 - 7kW

Setting range F1255-12 3x230V: 0 - 9kW

Setting range F1255-6 3x400V: 0 - 6.5 kW

Setting range F1255-12 & -16 3x400V: 0 - 9 kW

Factory setting F1255-6 1x230V: 4.5 kW

Factory setting F1255-6 3x230V: 4.5 kW

Factory setting F1255-12 1x230V: 7 kW

Factory setting F1255-12 3x230V: 9 kW

Factory setting F1255-6 3x400V: 6 kW

Factory setting F1255-12 & -16 3x400V: 6 kW

fuse size

Setting range: 1 - 400 A

Default values: 25 A

transformation ratio

Setting range: 300 - 3000

Factory setting: 300

Here you set the max. electrical output of the internal electrical addition in F1255 and the fuse size for the installation.

Here you can also check which current sensor is installed on which incoming phase to the property (this requires current sensors to be installed, see page 26). Check by marking "detect phase order" and pressing the OK button.

The results of these checks appear just below the menu selection "detect phase order".

Menu 5.1.14 - flow set. climate system

presettings

Setting range: radiator, floor heat., rad. + floor heat., DOT °C

Default value: radiator

Setting range DOT: -40.0 – 20.0 °C

Factory setting DOT: -18.0 °C

own setting

Setting range dT at DOT: 0.0 – 25.0

Factory setting dT at DOT: 10.0

Setting range DOT: -40.0 – 20.0 °C

Factory setting DOT: -18.0 °C

The type of heating distribution system the heating medium pump (GP1) works towards is set here.

dT at DOT is the difference in degrees between flow and return temperatures at dimensioned outdoor temperature.

Menu 5.1.22 - heat pump testing



NOTE

This menu is intended for testing F1255 according to different standards.

Use of this menu for other reasons may result in your installation not functioning as intended.

This menu contains several sub-menus, one for each standard.

Menu 5.1.24 - blockFreq

blockFreq 1

Selectable setting range in the display:

start: 17 – 115 Hz

stop: 22 – 120 Hz

Maximum setting range: 50 Hz.

blockFreq 2

Selectable setting range in the display:

start: 17 – 115 Hz

stop: 22 – 120 Hz

Maximum setting range: 50 Hz.

Here you can set a frequency range where the compressor is blocked. The parameters for the setting range differ depending on which product is controlled by the setting.



NOTE

A large blocked frequency range can cause the compressor to run jerkily.

Menu 5.2 - system settings

Make different system settings for the heat pump here, e.g. which accessories are installed.

There are two ways of activating connected accessories. You can either highlight the alternative in the list or use the automatic function "search installed acc.".

search installed acc.

Mark "search installed acc." and press the OK button to automatically find connected accessories for F1255.



Caution

Certain accessories are not found automatically but must be ticked off by hand, see menu 5.4.



NOTE

Only mark the option for ground water pump if the accessory AXC 40 is to be used to control the circulation pump.

Menu 5.3 - accessory settings

The operating settings for accessories that are installed and activated are made in the sub-menus for this.

Menu 5.3.1 - FLM

continuous pump op.

Setting range: on/off

Factory setting: off

time between defrosts

Setting range: 1 – 30 h

Default value: 10 h

months btwn filter alarms

Setting range: 1 – 12

Default value: 3

activate cooling

Setting range: on/off

Factory setting: off

continuous pump op.: Select for continuous operation of the circulation pump in the exhaust air module.

time between defrosts: Set the minimum time that must pass between defrostings of the heat exchanger in the exhaust air module.

When the exhaust air module is in operation the heat exchanger is cooled so that ice builds up on it. When too much ice builds up the heat transfer capacity of the heat exchanger is reduced and defrosting is required. Defrosting warms up the heat exchanger so that the ice melts and runs off via the condensation hose.

months btwn filter alarms: Set how many months should pass before the heat pump informs that it is time to clean the filter in the exhaust air module.

Clean the exhaust air module's air filter regularly, how often depends on the amount of dust in the ventilation air.

activate cooling: Activate cooling via the exhaust air module here. When the function has been activated, the cooling settings are displayed in the menu system.

See the accessory installation instructions for function description.

Menu 5.3.2 - shunt controlled add. heat

prioritised additional heat

Setting range: on/off

Factory setting: off

start diff additional heat

Setting range: 0 – 2000 DM

Default values: 400 DM

minimum running time

Setting range: 0 – 48 h

Default value: 12 h

min temp.

Setting range: 5 – 90 °C

Default value: 55 °C

mixing valve amplifier

Setting range: 0.1 – 10.0

Default value: 1.0

mixing valve step delay

Setting range: 10 – 300 s

Default values: 30 s

Set when the addition is to start, the minimum run time and the minimum temperature for external addition with shunt here. External addition with shunt is for example a wood/oil/gas/pellet boiler.

You can set shunt valve amplification and shunt valve waiting time.

Selecting "prioritised additional heat" uses the heat from the external additional heat instead of the heat pump. The shunt valve is regulated as long as heat is available, otherwise the shunt valve is closed.

See the accessory installation instructions for function description.

Menu 5.3.3 - extra climate system

use in heating mode

Setting range: on/off

Factory setting: on

use in cooling mode

Setting range: on/off

Factory setting: off

mixing valve amplifier

Setting range: 0.1 – 10.0

Default value: 1.0

mixing valve step delay

Setting range: 10 – 300 s

Default values: 30 s

In menu 5.3.3, you choose the climate system (2 - 8) you wish to set. In the next menu you can make settings for the climate system that you have selected.

If the heat pump is connected to more than one climate system, condensation may occur in these, if they are not intended for cooling.

To prevent condensation, check that "use in heating mode" is checked for the climate systems that are not intended for cooling. This means that the sub-shunts to the extra climate systems close, when cooling operation is activated.



Caution

This setting option only appears if "passive/active cooling 2-pipe" or "passive cooling 2-pipe" is activated in menu 5.2.

The shunt amplification and shunt waiting time for the different extra climate systems that are installed are also set here.

See the accessory installation instructions for function description.

Menu 5.3.4 - solar heating

start delta-T

Setting range: 1 - 40 °C

Default value: 8 °C

stop delta-T

Setting range: 0 - 40 °C

Default value: 4 °C

max. tank temperature

Setting range: 5 - 110 °C

Default value: 95 °C

max. solar collector temp.

Setting range: 80 - 200 °C

Default value: 125 °C

anti-freeze temperature

Setting range: -20 - +20 °C

Default value: 2 °C

start solar collector cooling

Setting range: 80 - 200 °C

Default value: 110 °C

passive recharging - activation temperature

Setting range: 50 - 125 °C

Default value: 110 °C

passive recharging - deactivation temperature

Setting range: 30 - 90 °C

Default value: 50 °C

active recharging - activating dT

Setting range: 8 - 60 °C

Default value: 40 °C

active recharging - deactivating dT

Setting range: 4 - 50 °C

Default value: 20 °C

start delta-T, stop delta-T: Here you can set the temperature difference between solar panel and solar tank at which the circulation pump is to start and stop.

max. tank temperature, max. solar collector temp.: Here you can set the maximum temperatures in tank respectively solar panel at which the circulation pump is to stop. This is to protect against excess temperatures in the solar tank.

If the unit has an anti-freeze function, solar panel cooling and/or passive/active recharging you can activate them here. When the function has been activated, you can make settings for them. "solar panel cooling", "passive recharging" and "active recharging" cannot be combined, only one function can be activated.

freeze protection

anti-freeze temperature: Here you can set the temperature in the solar panel at which the circulation pump is to start to prevent freezing.

solar panel cooling

start solar collector cooling: If the temperature in the solar panel is greater than this setting at the same time that the temperature in the solar tank is greater than the set maximum temperature, the external function for cooling is activated.

passive recharging

activation temperature: If the temperature in the solar panel is greater than this setting, the function activates. The function is blocked for an hour if the temperature of the brine in the heat pump (BT10) is higher than the set value for "max brine in" in menu 5.1.7

deactivation temperature: If the temperature in the solar panel is less than this setting, the function deactivates.

active recharging

activating dT: If the difference between the temperature in the solar panel (BT53) and the temperature of the brine in the heat pump (BT10) is greater than this setting the function is activated. The function is blocked for an hour if the temperature of the brine in the heat pump (BT10) is higher than the set value for "max brine in" in menu 5.1.7

deactivating dT: If the difference between the temperature in the solar panel (BT53) and the temperature of the brine in the heat pump (BT10) is less than this setting the function deactivates.

See the accessory installation instructions for function description.

Menu 5.3.6 - step controlled add. heat

start diff additional heat

Setting range: 0 – 2000 DM

Default values: 400 DM

diff. between additional steps

Setting range: 0 – 1000 DM

Default values: 100 DM

max step

Setting range
(binary stepping deactivated): 0 – 3

Setting range
(binary stepping activated): 0 – 7

Default value: 3

binary stepping

Setting range: on/off

Factory setting: off

Make settings for step controlled addition here. Step controlled addition is for example an external electric boiler.

It is possible, for example, to select when the additional heat is to start, to set the maximum number of permitted steps and whether binary stepping is to be used.

When binary stepping is deactivated (off), the settings refer to linear stepping.

See the accessory installation instructions for function description.

Menu 5.3.8 - hot water comfort

activating the mixing valve

Setting range: on/off

Factory setting: off

outgoing hot water

Setting range: 40 - 65 °C

Default value: 55 °C

mixing valve amplifier

Setting range: 0.1 – 10.0

Default value: 1.0

mixing valve step delay

Setting range: 10 – 300 s

Default values: 30 s

Make settings for the hot water comfort here.

See the accessory installation instructions for function description.

activating the mixing valve: Activated if mixer valve is installed and it is to be controlled from F1255. When the option is active, you can set the outgoing hot water temperature, shunt amplification and shunt waiting time for the mixer valve.

outgoing hot water: Set the temperature at which the mixing valve is to restrict hot water from the water heater.

Menu 5.3.11 - modbus

address

Factory setting: address 1

From and including Modbus 40 version 10 the address can be set between 1 - 247. Earlier versions have a static address.

See the accessory installation instructions for function description.

Menu 5.3.12 - exhaust/supply air module

lowest extract air temp.

Setting range: 0 – 10 °C

Default value: 5 °C

bypass at excess temperature

Setting range: 2 – 10 °C

Default value: 4 °C

bypass during heating

Setting range: on/off

Factory setting: off

cut-out value, exh. air temp.

Setting range: 5 – 30 °C

Default value: 25 °C

months btwn filter alarms

Setting range: 1 – 24

Default value: 3

lowest extract air temp.: Set the minimum extract air temperature to prevent the heat exchanger freezing.

bypass at excess temperature: If a room sensor is installed, set the over-temperature at which the bypass damper must open here.

months btwn filter alarms: Set how often the filter alarm must be displayed.

See the installation instructions for ERS for function description.

Menu 5.3.15 - GBM communication module

start diff additional heat

Setting range: 10 – 2,000 DM

Factory setting: 400 DM

hysteresis

Setting range: 10 – 2,000 DM

Factory setting: 100 DM

Make settings for the gas boiler GBM 10-15 here. For example . you can select when the gas boiler is to start. See the accessory installation instructions for a description of function.

Menu 5.3.16 - humidity sensor

prevent condensation, syst.

Setting range: on/off

Factory setting: off

limit RH in the room, syst.

Setting range: on/off

Factory setting: off

Here you select whether your system(s) is/are to limit the relative humidity level (RH) during heating or cooling operation.

You can also select to limit min. cooling supply to prevent condensation on pipes and components in the cooling system.

See the installation instructions for HTS 40 for function description.

Menu 5.3.21 - external energy meter

set mode

Setting range: energy per pulse / pulses per kWh

Default value: energy per pulse

energy per pulse

Setting range: 0 – 10000 Wh

Factory setting: 1000 Wh

pulses per kWh

Setting range: 0 – 10000

Factory setting: 500

The energy meter(s) are used to send pulse signals every time a certain amount of energy has been consumed.

energy per pulse: Here you set the amount of energy each pulse is to correspond to.

pulses per kWh: Here you set the number of pulses per kWh that are sent to F1255.

Menu 5.4 - soft in/outputs

Here you can select which input/output on the input board (AA3) the external contact function (page 26) must be connected to.

Selectable inputs on terminal block AUX 1-5 (AA3-X6:9-18) and output AA3-X7 on the input board.

Menu 5.5 - factory setting service

All settings can be reset (including settings available to the user) to default values here.



NOTE

When resetting, the start guide is displayed the next time the heat pump is restarted.

Menu 5.6 - forced control

You can force control the different components in the heat pump and any connected accessories here.



NOTE

Forced control is only intended to be used for troubleshooting purposes. Using the function in any other way may cause damage to the components in your climate system.

Menu 5.7 - start guide

When the heat pump is started for the first time the start guide starts automatically. Start it manually here.

See page 33 for more information about the start guide.

Menu 5.8 - quick start

It is possible to start the compressor from here.



Caution

There must be a heating or hot water demand to start the compressor.



Caution

Do not quick start the compressor too many times over a short period of time as this may damage the compressor and its surrounding equipment.

Menu 5.9 - floor drying function

length of period 1 – 7

Setting range: 0 – 30 days

Factory setting, period 1 – 3, 5 – 7: 2 days

Factory setting, period 4: 3 days

temp. period 1 – 7

Setting range: 15 – 70 °C

Default value:

temp. period 1	20 °C
temp. period 2	30 °C
temp. period 3	40 °C
temp. period 4	45 °C
temp. period 5	40 °C
temp. period 6	30 °C
temp. period 7	20 °C

Set the function for under floor drying here.

You can set up to seven period times with different calculated flow temperatures. If less than seven periods are to be used, set the remaining period times to 0 days.

Mark the active window to activate the underfloor drying function. A counter at the bottom shows the number of days the function has been active. The function counts degree minutes as during normal heating operation but for the supply temperatures that are set for the respective period.



NOTE

During under floor drying, the heating medium pump in 100% runs, regardless of the setting in menu 5.1.10.



TIP

If operating mode "add. heat only" is to be used, select it in menu 4.2.

For a more even flow temperature the addition can be started earlier by setting "start for addition" in menus 4.9.2 to -80. When set under floor drying periods have stopped, reset the menus 4.2 and 4.9.2 as per previous settings.

Menu 5.10 - change log

Read off any previous changes to the control system here.

The date, time and ID no. (unique to certain settings) and the new set value is shown for every change.



NOTE

The change log is saved at restart and remains unchanged after factory setting.

9 Service

Service actions



NOTE

Servicing should only be carried out by persons with the necessary expertise.

When replacing components on F1255 only replacement parts from NIBE may be used.

Emergency mode



NOTE

The switch (SF1) must not be moved to "I" or "Δ" until F1255 has been filled with water. Component parts in the product can be damaged.

Emergency mode is used in event of operational interference and in conjunction with service. Hot water is not produced in emergency mode.

Emergency mode is activated by setting switch (SF1) in mode "Δ". This means that:

- The status lamp illuminates yellow.
- The display is not lit and the control computer is not connected.
- The temperature at the immersion heater is controlled by the thermostat (FD1-BT30). It can be set either to 35 or 45 °C.
- The compressor and the brine system are off and only the heating medium pump and the electric additional heat are active. The additional heat power in emergency mode is set in the immersion heater board (AA1). See page 24 for instructions.

6 kW

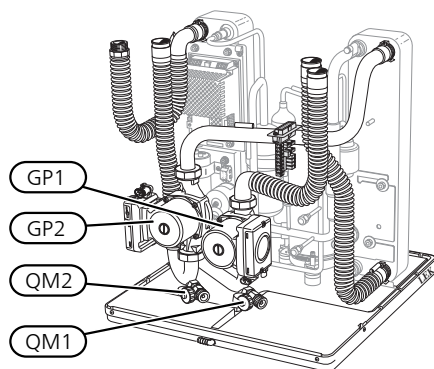

12 kW

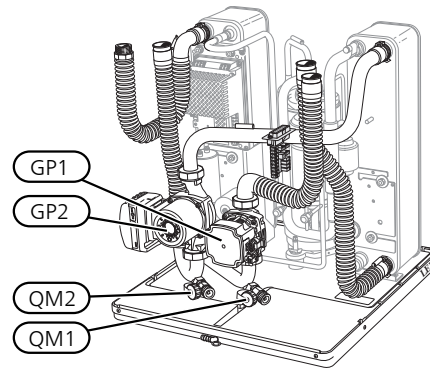

16 kW

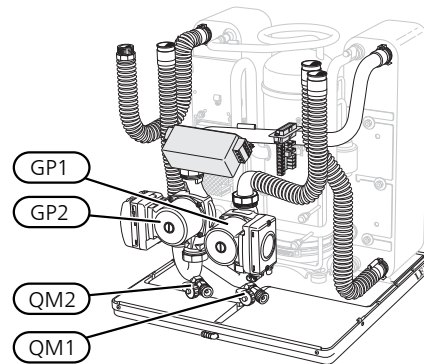

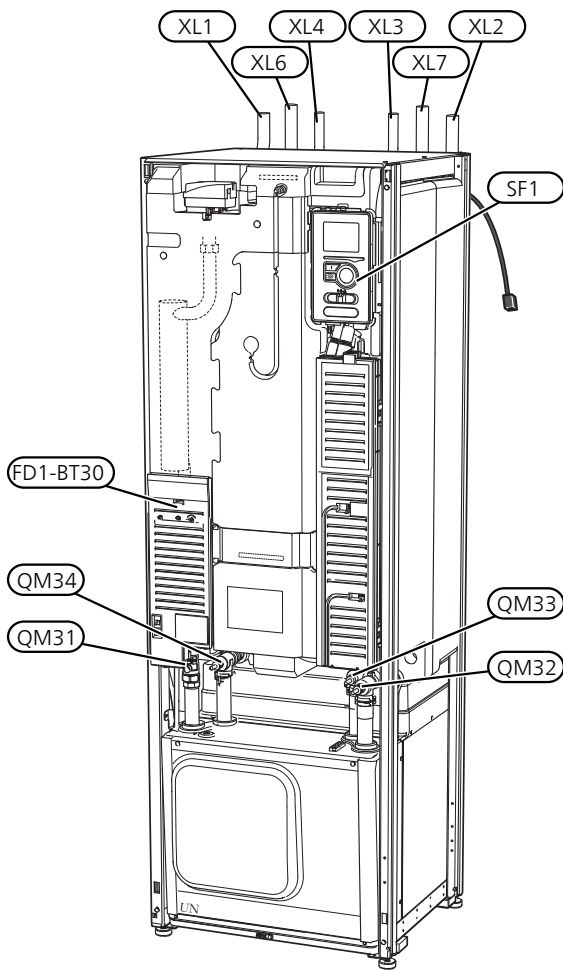

Draining the water heater

The siphon principle is used to empty the hot water heater. This can be done either via the drain valve on the incoming cold water pipe or by inserting a hose into the cold water connection.

Draining the climate system

In order to carry out service on the climate system, it may be easier to drain the system first. This can be done in different ways depending on what needs doing:



NOTE

There may be some hot water when draining the heating medium side/climate system. There is a risk of scalding.

Draining the heating medium side in the cooling module

If, for example, the heating medium pump requires replacing or the cooling module requires servicing, drain the heating medium side as follows:

1. Close the shut-off valves to heating medium side (QM31) and (QM32).
2. Connect a hose to the bleed valve (QM1) and open the valve. Some liquid will run out.

3. Air must get into the system for the remaining liquid to run out. To let in air, slacken off the connection slightly at the shut-off valve (QM32) that joins the heat pump with the cooling module.

When the heating medium side is empty, the required service can be carried out and/or replacement of any components carried out.

Draining the heating medium system in the heat pump

If F1255 requires servicing, drain the heating medium side as follows:

1. Close the shut-off valves outside the heat pump for the heating medium side (return and flow line).
2. Connect a hose to the bleed valve (QM1) and open the valve. Some liquid will run out.
3. Air must get into the system for the remaining liquid to run out. To let in air, slacken off the connection slightly at the shut-off valve that joins the heat pump with the cooling module (XL2).

When the heating medium side is empty, the required service can be carried out.

Draining the entire climate system

If the entire climate system requires draining, do this as follows:

1. Connect a hose to the bleed valve (QM1) and open the valve. Some liquid will run out.
2. Air must get into the system for the remaining liquid to run out. To allow air in, unscrew the bleed screw on the highest radiator in the house.

When the climate system is empty, the required service can be carried out.

Emptying the brine system

In order to service the brine system it may be easier to drain the system first. This can be done in different ways depending on what needs doing:

Draining the brine system in the cooling module

If, for example, the brine pump requires replacing or the cooling module requires servicing, drain the brine system by:

1. Close the shut-off valves to brine system (QM33) and (QM34).
2. Connect a hose to the drain valve (QM2), place the other opening of the hose in a container and open the valve. A small amount of brine will flow into the container.
3. Air must get into the system in order for the remaining brine to run out. To let in air, slacken off the connection slightly at the shut-off valve (QM33) that joins the heat pump with the cooling module.

When the brine system is empty, the required service can be carried out.

Draining the brine system in the heat pump

If the heat pump requires servicing, drain the brine system by:

1. Close the shut-off valve outside the heat pump for the brine system.
2. Connect a hose to the drain valve (QM2), place the other opening of the hose in a container and open the valve. A small amount of brine will flow into the container.
3. Air must get into the system for the remaining brine to run out. To let in air, slacken off the connection slightly at the shut-off valve that joins the brine side with the heat pump at connection (XL7).

When the brine system is empty, the required service can be carried out.

Helping the circulation pump to start

1. Shut off, F1255 by setting the switch ((SF1)) to "⏻".
2. Remove the front cover
3. Remove the cover for the cooling module.
4. Loosen the venting screw (QM5) with a screwdriver. Hold a cloth around the screwdriver blade as a small amount of water may run out.
5. Insert a screwdriver and turn the pump motor around.
6. Screw in the venting screw (QM5).
7. Start F1255 by setting the switch (SF1) to "I" and check whether the circulation pump works.

It is usually easier to start the circulation pump with F1255 running, switch (SF1) set to "I". If the circulation pump is helped to start while F1255 is running, be prepared for the screwdriver to jerk when the pump starts.

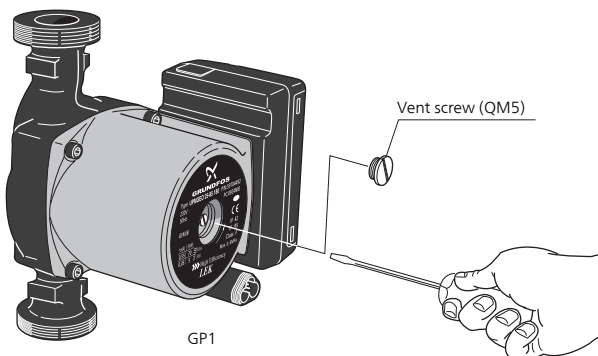

The image shows an example of what a circulation pump can look like.

Temperature sensor data

Temperature (°C)	Resistance (kOhm)	Voltage (VDC)
-40	351.0	3.256
-35	251.6	3.240
-30	182.5	3.218
-25	133.8	3.189
-20	99.22	3.150
-15	74.32	3.105
-10	56.20	3.047
-5	42.89	2.976
0	33.02	2.889
5	25.61	2.789
10	20.02	2.673
15	15.77	2.541
20	12.51	2.399
25	10.00	2.245
30	8.045	2.083
35	6.514	1.916
40	5.306	1.752
45	4.348	1.587
50	3.583	1.426
55	2.968	1.278
60	2.467	1.136
65	2.068	1.007
70	1.739	0.891
75	1.469	0.785
80	1.246	0.691
85	1.061	0.607
90	0.908	0.533
95	0.779	0.469
100	0.672	0.414

Pulling out the cooling module

The cooling module can be pulled out for service and transport.



NOTE

Shut off the heat pump and turn off the current on the safety breaker.



Caution

The cooling module is easy to remove if it is drained first (see page 55).



Caution

Remove the front cover according to the description on page 7.

- 1 Close the shut-off valves (QM31), (QM32), (QM33) and (QM34).

Drain the compressor module according to the instructions on page 55

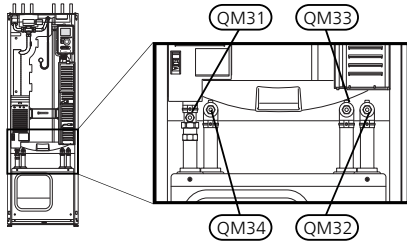

- 2 Pull off the lock catches.

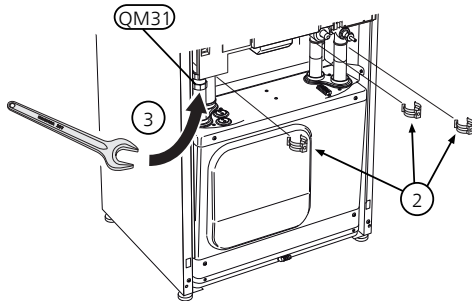

- 3 Disconnect the pipe connection at the shut-off valve (QM31).

- 4 Remove the two screws.

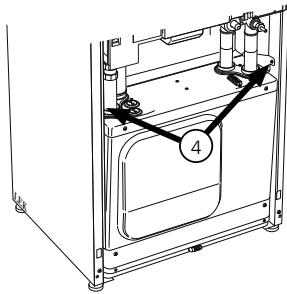

- 5 Remove the connection from the base card (AA2) using a screwdriver.

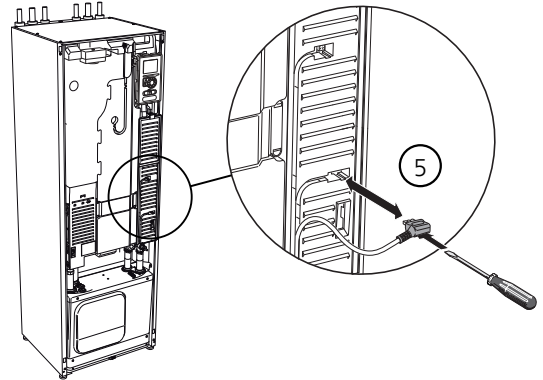

- 6 Disconnect the connectors (A) and (B) from the underside of the base card cabinet.

- 7 Disconnect the connector (C) from the immersion heater circuit board (AA1) using a screwdriver.

- 8 Disconnect the connector (D) from the joint circuit board (AA100).

- 9 Carefully pull out the cooling module.

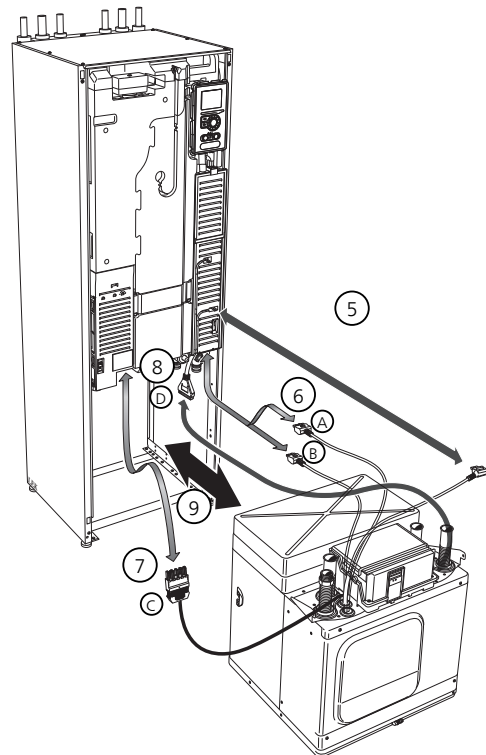

TIP

The cooling module is installed in reverse order.

NOTE

At reinstallation, the supplied O-rings must replace the existing ones at the connections to the heat pump (see image).

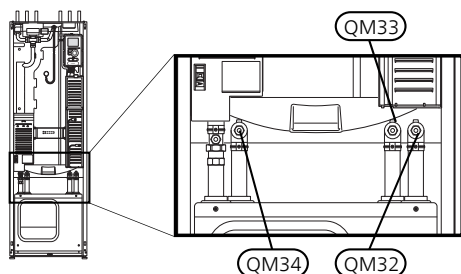

USB service outlet

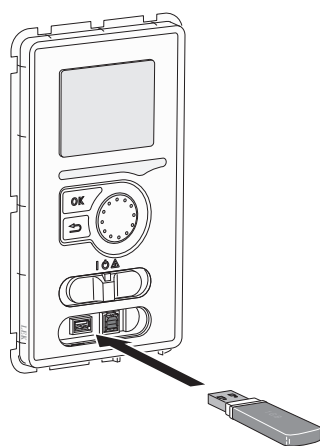

The display unit is equipped with a USB socket that can be used to update the software, save logged information and handle the settings in F1255.

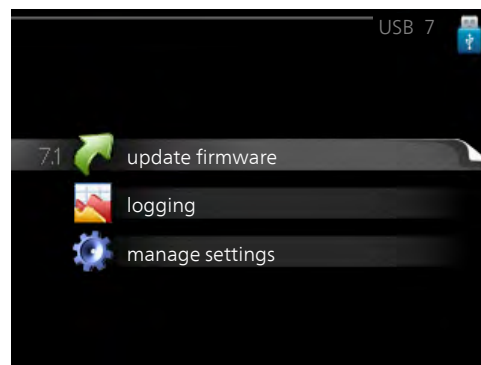
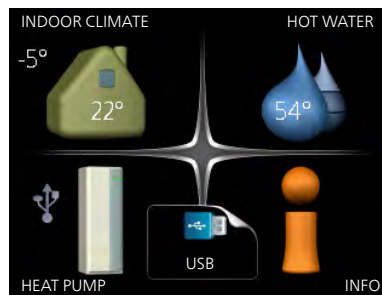

When a USB memory is connected a new menu (menu 7) appears in the display.

Menu 7.1 - update firmware

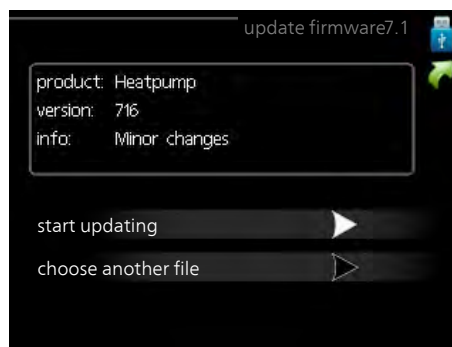

This allows you to update the software in F1255.

NOTE

For the following functions to work the USB memory must contain files with software for F1255 from NIBE.

The fact box at the top of the display shows information (always in English) of the most probable update that the update software has selected from the USB memory.

This information states which product the software is intended for, the software version and general information about them. If you wish to select another file than the one selected, the correct file can be selected by "choose another file".

start updating

Select "start updating" if you want to start the update. You are asked whether you really want to update the software. Respond "yes" to continue or "no" to undo.

If you responded "yes" to the previous question the update starts and you can now follow the progress of the update on the display. When the update is complete F1255 restarts.



NOTE

A software update does not reset the menu settings in F1255.



NOTE

If the update is interrupted before it is complete (for example power cut etc.), the software can be reset to the previous version if the OK button is held in during start up until the green lamp starts to illuminate (takes about 10 seconds).

choose another file

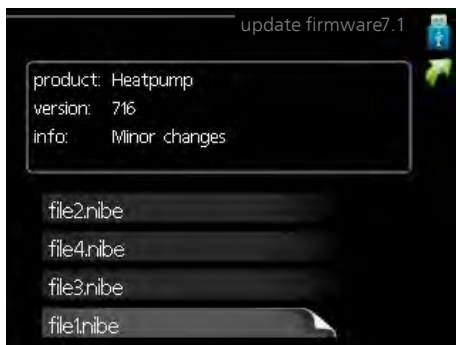

Select "choose another file" if you do not want to use the suggested software. When you scroll through the files, information about the marked software is shown in a fact box just as before. When you have selected a file with the OK button you will return to the previous page (menu 7.1) where you can choose to start the update.

Menu 7.2 - logging

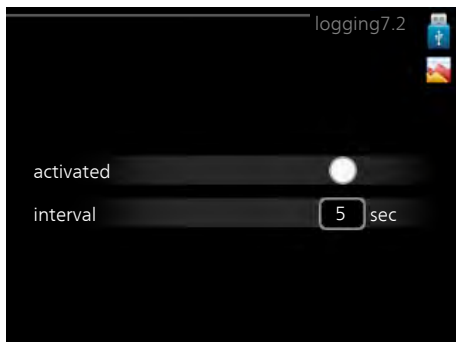

Setting range: 1 s – 60 min
Factory setting range: 5 s

Here you can choose how current measurement values from F1255 should be saved onto a log file on the USB memory.

1. Set the desired interval between loggings.
2. Tick "activated".
3. The present values from F1255 are saved in a file in the USB memory at the set interval until "activated" is unticked.



NOTE

Untick "activated" before removing the USB memory.

Menu 7.3 - manage settings

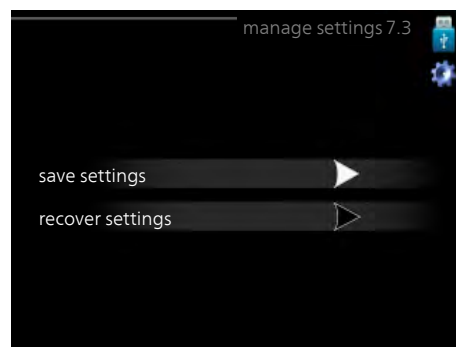

Here you can manage (save as or retrieve from) all the menu settings (user and service menus) in F1255 with a USB memory.

Via "save settings" you save the menu settings to the USB memory in order to restore them later or to copy the settings to another F1255.



NOTE

When you save the menu settings to the USB memory you replace any previously saved settings on the USB memory.

Via "recover settings" you reset all menu settings from the USB memory.



NOTE

Reset of the menu settings from the USB memory cannot be undone.

10 Disturbances in comfort

In most cases, the heat pump notes operational interference (operational interference can lead to disturbance in comfort) and indicates this with alarms and shows action instructions in the display.

Info-menu

All the heat pump measurement values are gathered under menu 3.1 in the heat pump menu system. Looking through the values in this menu can often simplify finding the source of the fault. See help menu or user manual for more information about menu 3.1.

Manage alarm

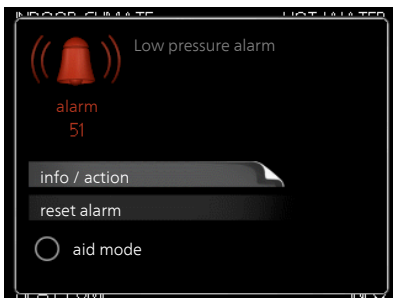

In the event of an alarm, some kind of malfunction has occurred, which is indicated by the status lamp changing from green continuously to red continuously. In addition, an alarm bell appears in the information window.

Alarm

In the event of an alarm with a red status lamp a malfunction has occurred that the heat pump cannot remedy itself. In the display, by turning the control knob and pressing the OK button, you can see the type of alarm it is and reset it. You can also choose to set the heat pump to aid mode.

info / action Here you can read what the alarm means and receive tips on what you can do to correct the problem that caused the alarm.

reset alarm In many cases, it is sufficient to select "reset alarm" in order for the product to revert to normal operation. If a green light comes on after selecting "reset alarm", the alarm has been remedied. If a red light is still visible and a menu called "alarm" is visible in the display, the problem that caused the alarm remains. If the alarm disappears and then returns, see the troubleshooting section (page 60).

aid mode "aid mode" is a type of emergency mode. This means that the heat pump produces heat and/or hot water despite there being some kind of problem. This can mean that the heat pump's compressor is not running. In this case the immersion heater produces heat and/or hot water.



NOTE

To select aid mode an alarm action must be selected in the menu 5.1.4.



Caution

Selecting "aid mode" is not the same as correcting the problem that caused the alarm. The status lamp will therefore continue to be red.

Troubleshooting

If the operational interference is not shown in the display the following tips can be used:

Basic actions

Start by checking the following items:

- The switch's (SF1) position.
- Group and main fuses of the accommodation.
- The property's earth circuit breaker.
- The heat pump's miniature circuit breaker (FA1).
- The heat pump's temperature limiter (FD1).
- Correctly set load monitor (if installed).

Low hot water temperature or no hot water

- Closed or choked filling valve
 - Open the valve.
- Heat pump in incorrect operating mode.
 - If mode "manual" is selected, select "addition".
- Large hot water consumption.
 - Wait until the hot water has heated up. Temporarily increased hot water capacity (temporary lux) can be activated in menu 2.1.
- Too low hot water setting.
 - Enter menu 2.2 and select a higher comfort mode.
- Too low or no operating prioritisation of hot water.
 - Enter menu 4.9.1 and increase the time for when hot water is to be prioritised.

Low room temperature

- Closed thermostats in several rooms.
 - Set the thermostats to max, in as many rooms as possible. Adjust the room temperature via menu 1.1, instead of choking the thermostats.
- Heat pump in incorrect operating mode.
 - Enter menu 4.2. If mode "auto" is selected, select a higher value on "stop heating" in menu 4.9.2.
 - If mode "manual" is selected, select "heating". If this is not enough, select "addition".
- Too low set value on the automatic heating control.
 - Enter menu 1.1 "temperature" and adjust the offset heating curve up. If the room temperature is only low in cold weather the curve slope in menu 1.9.1 "heating curve" needs adjusting up.
- Too low or no operating prioritisation of heat.
 - Enter menu 4.9.1 and increase the time for when heating is to be prioritised.

- "Holiday mode" activated in menu 4.7.
 - Enter menu 4.7 and select "Off".
- External switch for changing the room heating activated.
 - Check any external switches.
- Air in the climate system.
 - Vent the climate system (see page 32).
- Closed valves (QM20), (QM32) to the climate system. Closed valves to the climate system. (QM40), (QM41) to the climate system.
 - Open the valves.

High room temperature

- Too high set value on the automatic heating control.
 - Enter menu 1.1 (temperature) and reduce the offset heating curve. If the room temperature is only high in cold weather the curve slope in menu 1.9.1 "heating curve" needs adjusting down.
- External switch for changing the room heating activated.
 - Check any external switches.

Uneven room temperature.

- Incorrectly set heating curve.
 - Adjust the heating curve in menu 1.9.1..
- Too high set value on "dT at DOT"..
 - Enter menu 5.1.14 (flow set. climate system) and reduce the value of "dT at DOT".
- Uneven flow over the radiators.
 - Adjust the flow distribution between the radiators.

Low system pressure

- Not enough water in the climate system.
 - Top up the water in the climate system (see page 32).

Low or a lack of ventilation

This part of the fault-tracing chapter only applies if the NIBE FLM accessory is installed.

- Filter (HQ10) blocked.
 - Clean or replace the filter.
- The ventilation is not adjusted.
 - Order/implement ventilation adjustment.
- Exhaust air device blocked or throttled down too much.
 - Check and clean the exhaust air devices.
- Fan speed in reduced mode.
 - Enter menu 1.2 and select "normal".
- External switch for changing the fan speed activated.
 - Check any external switches.

High or distracting ventilation

This part of the fault-tracing chapter only applies if the NIBE FLM accessory is installed.

- Filter blocked.
 - Clean or replace the filter.
- The ventilation is not adjusted.
 - Order/implement ventilation adjustment.
- Fan speed in forced mode.
 - Enter menu 1.2 and select "normal".
- External switch for changing the fan speed activated.
 - Check any external switches.

The compressor does not start

- There is no heating requirement.
 - The heat pump does not call on heating nor hot water.
- Compressor blocked due to the temperature conditions.
 - Wait until the temperature is within the product's working range.
- Minimum time between compressor starts has not been reached.
 - Wait 30 minutes and then check if the compressor has started.
- Alarm tripped.
 - Follow the display instructions.

Whining noise in the radiators

- Closed thermostats in the rooms and incorrectly set heating curve.
 - Set the thermostats to max. in as many rooms as possible. Adjust the heating curve via menu 1.1, instead of choking the thermostats.
- Circulation pump speed set too high.
 - Enter menu 5.1.11 (pump speed heating medium) and reduce the speed of the circulation pump.
- Uneven flow over the radiators.
 - Adjust the flow distribution between the radiators.

Gurgling sound

This part of the troubleshooting chapter only applies if the NIBE FLM accessory is installed.

- Not enough water in the water seal.
 - Refill the water seal with water.
- Choked water seal.
 - Check and adjust the condensation water hose.

11 Accessories

Not all accessories are available on all markets.

Accessory card AXC 40

This accessory is used to enable connection and control of shunt controlled additional heat, step controlled additional heat, external circulation pump or ground water pump.

Part no. 067 060

Active/Passive cooling HPAC 40

The accessory HPAC 40 is a climate exchange module that is to be included in a system with F1255.

Part no. 067 076

Auxiliary relay HR 10

Auxiliary relay HR 10 is used to control external 1 to 3 phase loads such as oil burners, immersion heaters and pumps.

Part no 067 309

Base extension EF 45

This accessory is used to create a larger connection area under F1255.

Part no. 067 152

Buffer vessel UKV

UKV 40

Part no. 088 470

UKV 200

Part no. 080 300

UKV 500

Part no. 080 302

UKV 100

Part no. 088 207

UKV 300

Part no. 080 301

Communications module MODBUS 40

MODBUS 40 enables F1255 to be controlled and monitored using a DUC (computer sub-centre) in the building. Communication is then performed using MODBUS-RTU.

Part no 067 144

Communications module SMS 40

When there is no internet connection, you can use the accessory SMS 40 to control F1255 via SMS.

Part no 067 073

Exhaust air module NIBE FLM

NIBE FLM is an exhaust air module designed to combine recovery of mechanical exhaust air with ground source heating.

NIBE FLM

Part no. 067 011

Bracket pack FLM

Part no. 067 083

External electric additional heat ELK

These accessories require accessories card AXC 40 (step controlled addition).

ELK 15

15 kW, 3 x 400 V

Part no. 069 022

ELK 213

7-13 kW, 3 x 400 V

Part no. 069 500

Extra shunt group ECS 40/ECS 41

This accessory is used when F1255 is installed in houses with two or more different heating systems that require different supply temperatures.

ECS 40 (Max 80 m²)

Part no 067 287

ECS 41 (approx. 80-250 m²)

Part no 067 288

Filling valve kit KB 25/32

Valve kit for filling brine in the collector hose. Includes particle filter and insulation.

KB 25 (max. 12 kW)

Part no 089 368

KB 32 (max. 30 kW)

Part no 089 971

Free cooling PCS 44

This accessory is used when F1255 is installed in an installation with passive cooling.

Part no 067 296

Gas accessory

Communications module OPT 10

OPT 10 is used to enable connection and control of gas boiler NIBE GBM 10-15.

Part no. 067 513

Humidity sensor HTS 40

This accessory is used to show and regulate humidity and temperatures during both heating and cooling operation.

Part no. 067 538

Level monitor NV 10

Level monitor for extended checks of the brine level.

Part no. 089 315

Measurement kit for solar generated electricity EME 10

EME 10 is used to optimise the use of solar generated electricity.

Part no. 067 541

Passive cooling

PCM 40

Part no. 067 077

PCM 42

Part no. 067 078

Pool heating POOL 40

POOL 40 is used to enable pool heating with F1255.

Part no 067 062

Room unit RMU 40

RMU 40 means that control and monitoring of F1255 can be carried out in a different part of your home to where it is located.

Part no 067 064

Solar package NIBE PV

Solar panel package with extremely long service-life to produce your own electricity.

3 kW

10 Solar panels

6 kW

20 Solar panels

9 kW

30 Solar panels

12 kW

40 Solar panels

21 kW

70 Solar panels

Ventilation heat exchanger

This accessory is used to supply the accommodation with energy that has been recovered from the ventilation air. The unit ventilates the house and heats the supply air as necessary.

ERS 10-500

Part no. 066 078

ERS 20-250

Part no. 066 068

Water heater/Accumulator tank

AHPS

Accumulator tank without an immersion heater with solar coil (copper) and a hot water coil (stainless steel).

Part no. 056 283

AHP

Volume expansion vessel that is primarily used for expanding the volume together with AHPS.

Part no. 056 284

AHPH

Accumulator tank without an immersion heater with integrated hot water coil (stainless steel).

Part no. 081 036

12 Technical data

Dimensions and setting-out coordinates

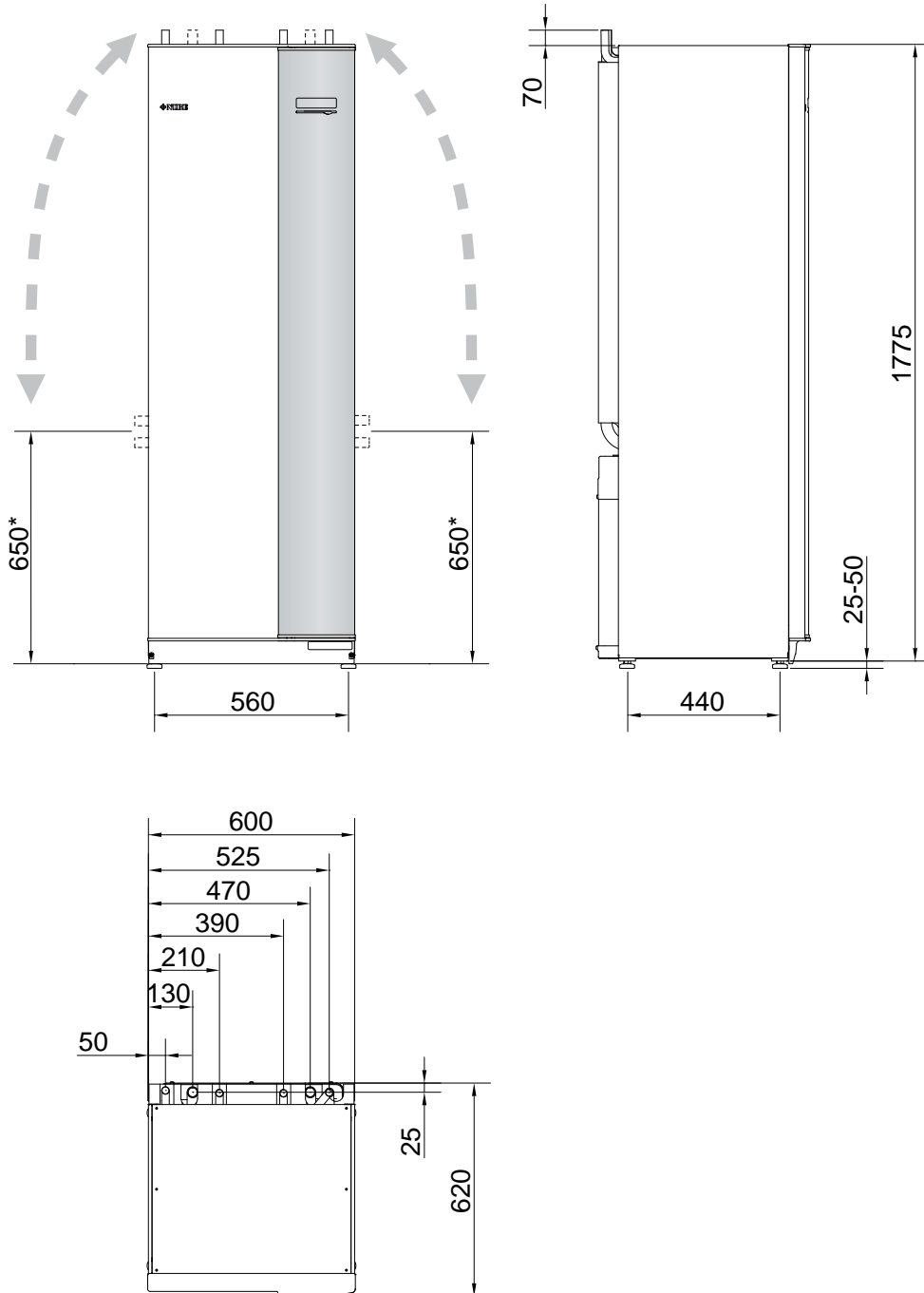

* This dimension applies at 90° angle on the brine pipes (side connection). The dimension can vary approx. ±100 mm in height as the brine pipes partially consist of flexible pipes.

Technical specifications



1x230V

F1255-6		
Electrical data		
Rated voltage		230V ~ 50Hz
Max operating current including 0 – 0.5 kW immersion heater (Recommended fuse rating).	A _{rms}	15(16)
Max operating current including 1 – 1.5 kW immersion heater (Recommended fuse rating).	A _{rms}	20(20)
Max operating current including 2 – 2.5 kW immersion heater (Recommended fuse rating).	A _{rms}	24(25)
Max operating current including 3 – 4 kW immersion heater (Recommended fuse rating).	A _{rms}	31(32)
Max operating current including 4.5 kW immersion heater (Recommended fuse rating).	A _{rms}	33(40)
Additional power	kW	0.5/1/1.5/2/2.5/3 /3.5/4/4.5

F1255-12		
Electrical data		
Rated voltage		230 V ~ 50 Hz
Max operating current including 0 – 1 kW immersion heater (Recommended fuse rating).	A _{rms}	26(32)
Max operating current including 2 – 4 kW immersion heater (Recommended fuse rating).	A _{rms}	39(40)
Max operating current including 5 – 7 kW immersion heater (Recommended fuse rating).	A _{rms}	52(63)
Additional power	kW	1/2/3/4/5/6/7

3x230V

F1255-6		
Electrical data		
Rated voltage		230V 3 ~ 50Hz
Max operating current including 0 – 1 kW immersion heater (Recommended fuse rating).	A _{rms}	16(16)
Max operating current including 1.5 – 4.5 kW immersion heater (Recommended fuse rating).	A _{rms}	20(20)
Additional power	kW	0.5/1/1.5/2/2.5/3 /3.5/4/4.5

F1255-12		
Electrical data		
Rated voltage		230V 3 ~ 50Hz
Max operating current including 2 – 4 kW immersion heater (Recommended fuse rating).	A _{rms}	28(32)
Max operating current including 6 kW immersion heater (Recommended fuse rating).	A _{rms}	36(40)
Max operating current including 9 kW immersion heater (Recommended fuse rating).	A _{rms}	46(50)
Additional power	kW	1/2/3/4/5/6/7/8/9

3x400V

F1255-6		
Electrical data		
Rated voltage		400V 3N ~ 50Hz
Max operating current including 0 kW immersion heater (Recommended fuse rating).	A _{rms}	12(16)
Max operating current including 0.5 – 6.5 kW immersion heater (Recommended fuse rating).	A _{rms}	16(16)
Additional power	kW	0.5/1/1.5/2/2.5/3 /3.5/4/4.5/5/5.5/6/6.5

F1255-12		
Electrical data		
Rated voltage		400V 3N ~ 50Hz
Max operating current including 0 kW immersion heater (Recommended fuse rating).	A _{rms}	9(10)
Max operating current including 1 kW immersion heater (Recommended fuse rating).	A _{rms}	12(16)
Max operating current including 2 – 4 kW immersion heater (Recommended fuse rating).	A _{rms}	16(20)
Max operating current including 5 – 7 kW immersion heater (Recommended fuse rating).	A _{rms}	21(25)
Max operating current including 9 kW immersion heater, requires reconnection (Recommended fuse rating).	A _{rms}	24(25)
Additional power	kW	1/2/3/4/5/6/7 (switchable to 2/4/6/9)

F1255-16		
Electrical data		
Rated voltage		400V 3N ~ 50Hz
Max operating current including 0 kW immersion heater (Recommended fuse rating).	A _{rms}	10(10)
Max operating current including 1 kW immersion heater (Recommended fuse rating).	A _{rms}	13(16)
Max operating current including 2 – 4 kW immersion heater (Recommended fuse rating).	A _{rms}	17(20)
Max operating current including 5 – 7 kW immersion heater (Recommended fuse rating).	A _{rms}	21(25)
Max operating current including 9 kW immersion heater, requires reconnection (Recommended fuse rating).	A _{rms}	24(25)
Additional power	kW	1/2/3/4/5/6/7 (switchable to 2/4/6/9)
Short circuit power (Ssc)*	MVA	2.0

*) This equipment complies with IEC 61000-3-12, on the condition that the short circuit power Ssc is greater than or equal to 2.0 MVA at the connection point between the customer installation electrical supply and the mains network. It is the responsibility of the installer or user to ensure, through consultation with the distribution network operator if required, that the equipment is only connected to a supply with a short circuit power Ssc equal to or greater than 2.0 MVA.

1x230V, 3x230V and 3x400V

		F1255-6	F1255-12	F1255-16
Output data according to EN 14511				
Heating capacity (P _H)	kW	1.5 – 6	3 – 12	4 – 16
0/35 nominal				
Heating capacity (P _H)	kW	3.15	5.06	8.89
Supplied power (P _E)	kW	0.67	1.04	1.83
COP		4.72	4.87	4.85
0/45 nominal				
Heating capacity (P _H)	kW	2.87	4.78	8.63
Supplied power (P _E)	kW	0.79	1.27	2.29
COP		3.61	3.75	3.77
10/35 nominal				
Heating capacity (P _H)	kW	4.30	6.33	11.22
Supplied power (P _E)	kW	0.66	1.03	1.84
COP		6.49	6.12	6.11
10/45 nominal				
Heating capacity (P _H)	kW	3.98	5.98	10.92
Supplied power (P _E)	kW	0.83	1.30	2.32
COP		4.79	4.59	4.72
SCOP according to EN 14825				
Rated heating output (P _{designh})	kW	6	12	16
SCOP _{EN14825} cold climate 35 °C / 55 °C		5.5 / 4.1	5.4 / 4.3	5.5 / 4.2
SCOP _{EN14825} average climate, 35 °C / 55 °C		5.2 / 4.0	5.2 / 4.1	5.2 / 4.1
Energy rating, average climate				
Efficiency class, room heating 35 °C / 55 °C ¹⁾		A++ / A++	A++ / A++	A++ / A++
Space heating efficiency class of the system 35 °C / 55 °C ²⁾		A+++ / A+++	A+++ / A+++	A+++ / A+++
Efficiency class, hot water / charging profile ³⁾		A / XL	A / XL	A / XL
Noise				
Sound power level (L _{WA}) acc to EN 12102 at 0/35	dB(A)	36 – 43	36 – 47	36 – 47
Sound pressure level (L _{PA}) calculated values according to EN ISO 11203 at 0/35 and 1m range	dB(A)	21 – 28	21 – 32	21 – 32
Electrical data				
Output, Brine pump	W	10 – 87	3 – 180	20 – 180
Output, Heating medium pump	W	2 – 63	2 – 60	10 – 87
Enclosure class			IP21	
Refrigerant circuit				
Type of refrigerant			R407C	
GWP refrigerant			1,774	
Volume	kg	1.16	2.0	2.2
CO ₂ equivalent	ton	2.06	3.55	3.90
Cut-out value pressure switch HP / LP	MPa		3.2 (32 bar) / 0.15 (1.5 bar)	
Difference pressure switch HP / LP	MPa		-0.7 (-7 bar) / 0.15 (1.5 bar)	
Brine circuit				
Min/max system pressure brine	MPa		0.05 (0.5 bar) / 0.45 (4.5 bar)	
Nominal flow	l/s	0.18	0.29	0.51
Max external avail. press at nom flow	kPa	64	115	95
Min/Max incoming Brine temp	°C		see diagram	
Min. outgoing brine temp.	°C		-12	
Heating medium circuit				
Min/Max system pressure heating medium	MPa		0.05 (0.5 bar) / 0.45 (4.5 bar)	
Nominal flow	l/s	0.08	0.12	0.22
Max external avail. press at nom flow	kPa	69	73	71
Min/max HM-temp	°C		see diagram	
Pipe connections				
Brine ext diam. CU pipe	mm		28	
Heating medium ext diam. CU pipes	mm	22	28	
Hot water connection external diam	mm		22	
Cold water connection external diam	mm		22	
Water heater				
Volume water heater	l		approx. 180	
Max pressure in water heater	MPa		1.0 (10 bar)	

		F1255-6			F1255-12			F1255-16					
Hot water heating capacity (comfort mode Normal) According to EN16147													
Amount of hot water (40 °C)		245			240			240					
COP _{DHW} (load profile XL)		2.6			2.5			2.5					
Compressor oil													
Oil type		POE											
Volume		l			0.68			0.9			1.45		
Dimensions and weight													
Width		mm			600								
Depth		mm			620								
Height		mm			1800								
Required ceiling height ⁴⁾		mm			1950								
Corrosion protection ⁵⁾		Cu	Rf	E	Cu	Rf	E	Cu	Rf	E			
Weight complete heat pump		kg	220	200	235	230V: 240	230V: 220	230V: 260	255	235	270		
Weight only cooling module		kg	90			230V: 110 400V: 120			125				
Part number, 1x230V					065 273				065 406				
Part number, 3x230V, with energy meter					065 316				065 405				
Part number, 3x400V		065 267	065 269	065 268	065 400	065 402	065 401	065 059	065 257	065 239			
Part number, 3x400V, with energy meter					065 319	065 270				065 404	065 403	065 314	065 258

1)Scale for the product's efficiency class room heating: A++ – G.

2)Scale for the system's efficiency class room heating: A+++ – G. Reported efficiency for the system takes the product's temperature regulator into account.

3)Scale for efficiency class hot water: A – G.

4)With feet removed, the required ceiling height is approx. 1,930 mm.

5)Cu: copper, Rf: stainless steel, E: enamel.

Working range heat pump, compressor operation

The compressor provides a supply temperature up to 65 °C, at 0 °C incoming brine temperature, the remainder (up to 70°C) is obtained using the additional heat.

F1255-6, -12, -16

This diagram shows the working range below 75 % for F1255-6 and the entire working range for F1255-12, -16.

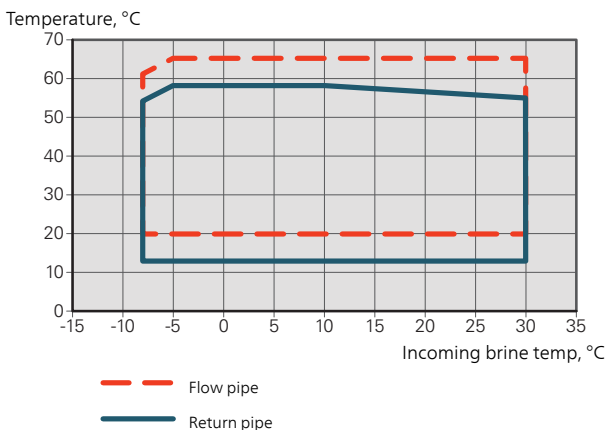

F1255-6

This diagram shows the working range above 75 % for F1255-6.

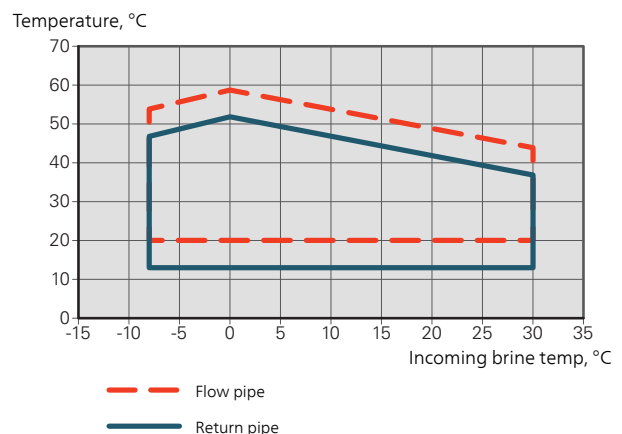

Caution

For operation of F1255-6 above 75% compressor speed, unlock in menu 5.1.24. This can produce a louder noise level than the value stated in the technical specifications.

Diagram, dimensioning compressor speed

Heating mode 35 °C

Use this diagram to dimension the heat pump.
The percentage show approximate compressor speed.

F1255-6

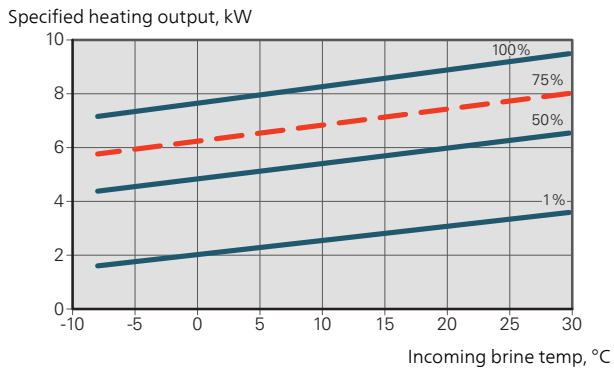

F1255-12 230V

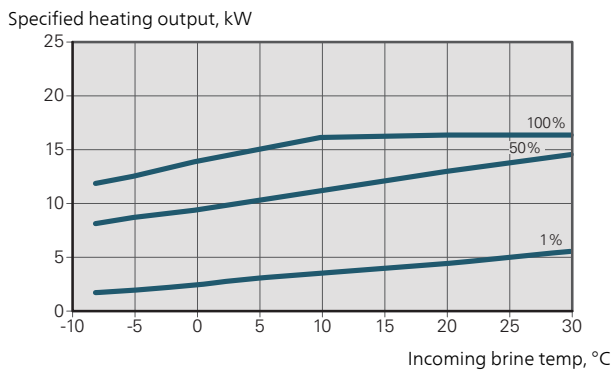

F1255-12 400V

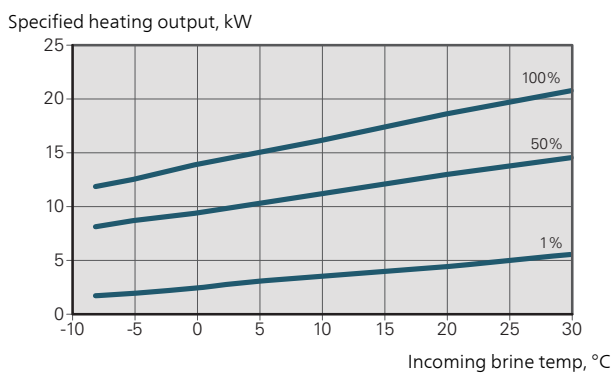

F1255-16

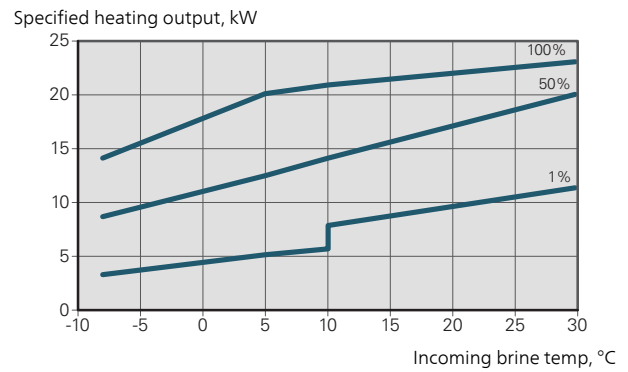

Cooling mode (Accessory required)



Caution

To dimension heating dump, see the diagram for heating operation.

Supply temperature, heating medium 35 °C

F1255-6

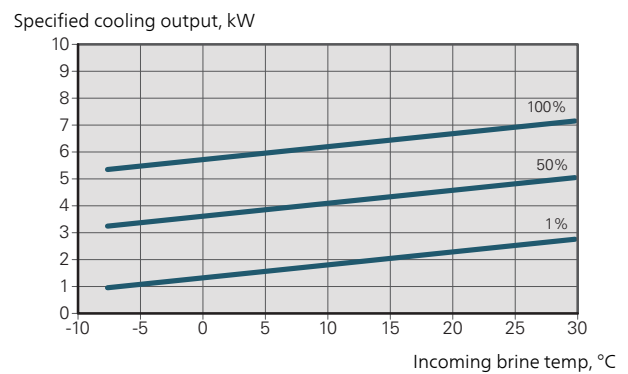

F1255-12 230V

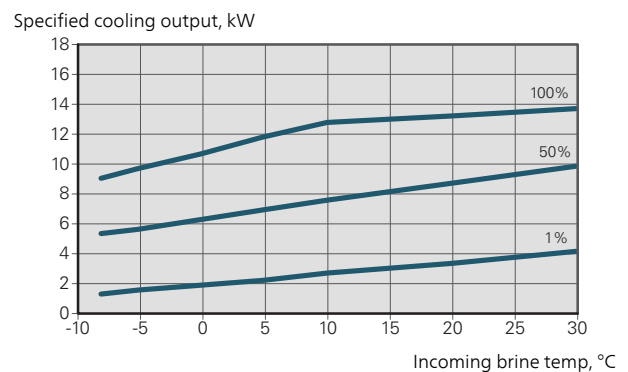

F1255-12 400V

Specified cooling output, kW

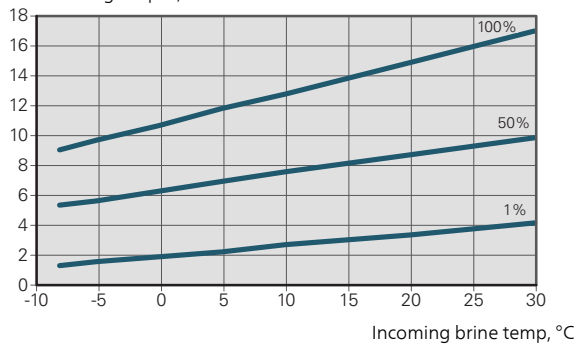

F1255-12 400V

Specified cooling output, kW

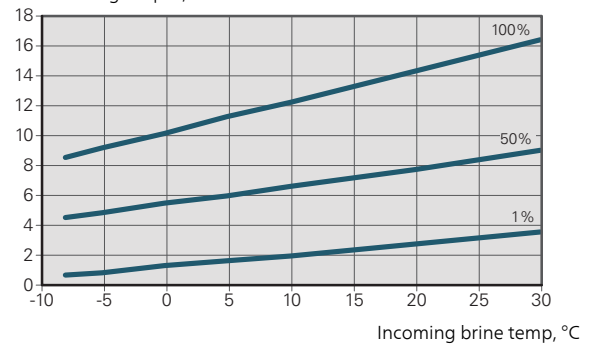

F1255-16

Specified cooling output, kW

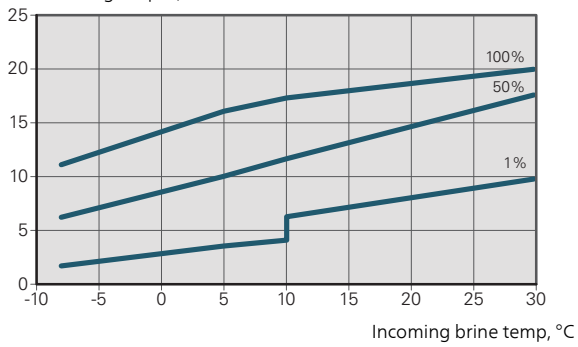

F1255-16

Specified cooling output, kW

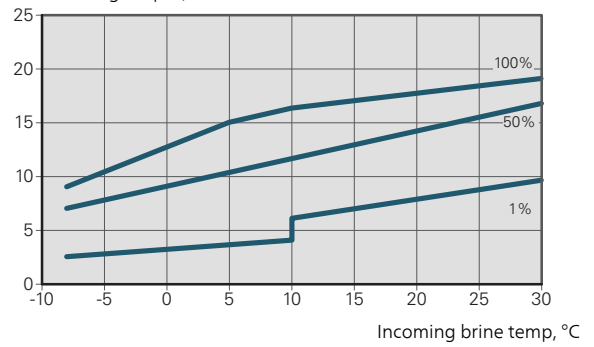

Supply temperature, heating medium 50 °°C

F1255-6

Specified cooling output, kW

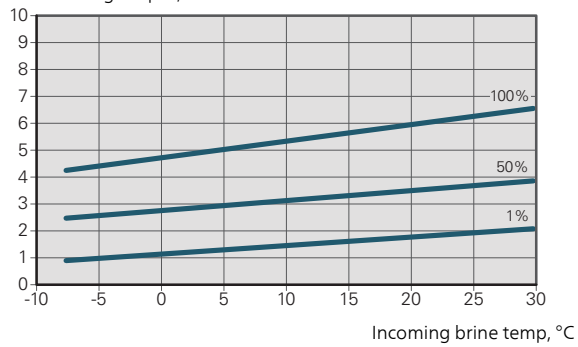

F1255-12 230V

Specified cooling output, kW

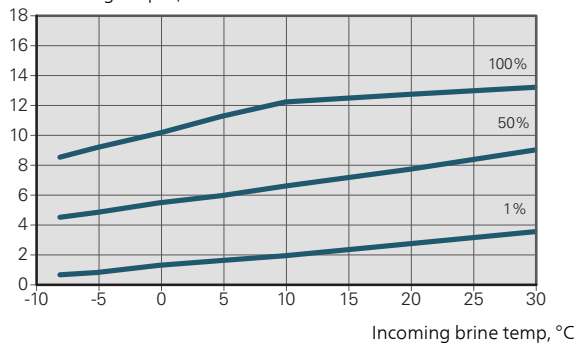

Energy labelling

Information sheet

Supplier		NIBE AB	
Model		F1255-6 1x230V	F1255-12 1x230V
Temperature application	°C	35 / 55	35 / 55
Declared load profile for water heating		XL	XL
Seasonal space heating energy efficiency class, average climate		A++ / A++	A++ / A++
Water heating energy efficiency class, average climate		A	A
Rated heat output (P_{designh}), average climate	kW	6	12
Annual energy consumption space heating, average climate	kWh	2,188 / 2,875	4,582 / 6,213
Annual energy consumption water heating, average climate	kWh	1,642	1,709
Seasonal space heating energy efficiency, average climate	%	200 / 150	201 / 157
Water heating energy efficiency, average climate	%	102	98
Sound power level L_{WA} indoors	dB	42	44
Rated heat output (P_{designh}), cold climate	kW	6	12
Rated heat output (P_{designh}), warm climate	kW	6	12
Annual energy consumption space heating, cold climate	kWh	2,481 / 3,287	5,292 / 7,173
Annual energy consumption water heating, cold climate	kWh	1,642	1,709
Annual energy consumption space heating, warm climate	kWh	1,408 / 1,852	2,928 / 3,999
Annual energy consumption water heating, warm climate	kWh	1,642	1,709
Seasonal space heating energy efficiency, cold climate	%	211 / 157	208 / 162
Water heating energy efficiency, cold climate	%	102	98
Seasonal space heating energy efficiency, warm climate	%	201 / 151	204 / 158
Water heating energy efficiency, warm climate	%	102	98
Sound power level L_{WA} outdoors	dB	-	-

Supplier		NIBE AB	
Model		F1255-6 3x230V	F1255-12 3x230V
Temperature application	°C	35 / 55	35 / 55
Declared load profile for water heating		XL	XL
Seasonal space heating energy efficiency class, average climate		A++ / A++	A++ / A++
Water heating energy efficiency class, average climate		A	A
Rated heat output ($P_{designh}$), average climate	kW	6	12
Annual energy consumption space heating, average climate	kWh	2,188 / 2,875	4,582 / 6,213
Annual energy consumption water heating, average climate	kWh	1,642	1,709
Seasonal space heating energy efficiency, average climate	%	200 / 150	201 / 157
Water heating energy efficiency, average climate	%	102	98
Sound power level L_{WA} indoors	dB	42	44
Rated heat output ($P_{designh}$), cold climate	kW	6	12
Rated heat output ($P_{designh}$), warm climate	kW	6	12
Annual energy consumption space heating, cold climate	kWh	2,481 / 3,287	5,292 / 7,173
Annual energy consumption water heating, cold climate	kWh	1,642	1,709
Annual energy consumption space heating, warm climate	kWh	1,408 / 1,852	2,928 / 3,999
Annual energy consumption water heating, warm climate	kWh	1,642	1,709
Seasonal space heating energy efficiency, cold climate	%	211 / 157	208 / 162
Water heating energy efficiency, cold climate	%	102	98
Seasonal space heating energy efficiency, warm climate	%	201 / 151	204 / 158
Water heating energy efficiency, warm climate	%	102	98
Sound power level L_{WA} outdoors	dB	-	-

Supplier		NIBE AB		
Model		F1255-6 3x400V	F1255-12 3x400V	F1255-16 3x400V
Temperature application	°C	35 / 55	35 / 55	35 / 55
Declared load profile for water heating		XL	XL	XL
Seasonal space heating energy efficiency class, average climate		A++ / A++	A++ / A++	A++ / A++
Water heating energy efficiency class, average climate		A	A	A
Rated heat output ($P_{designh}$), average climate	kW	6	12	16
Annual energy consumption space heating, average climate	kWh	2,188 / 2,875	4,582 / 6,213	6,373 / 8,167
Annual energy consumption water heating, average climate	kWh	1,642	1,709	1,709
Seasonal space heating energy efficiency, average climate	%	200 / 150	201 / 157	199 / 154
Water heating energy efficiency, average climate	%	102	98	98
Sound power level L_{WA} indoors	dB	42	44	42
Rated heat output ($P_{designh}$), cold climate	kW	6	12	16
Rated heat output ($P_{designh}$), warm climate	kW	6	12	16
Annual energy consumption space heating, cold climate	kWh	2,481 / 3,287	5,292 / 7,173	7,218 / 9,434
Annual energy consumption water heating, cold climate	kWh	1,642	1,709	1,709
Annual energy consumption space heating, warm climate	kWh	1,408 / 1,852	2,928 / 3,999	4,169 / 5,386
Annual energy consumption water heating, warm climate	kWh	1,642	1,709	1,709
Seasonal space heating energy efficiency, cold climate	%	211 / 157	208 / 162	211 / 159
Water heating energy efficiency, cold climate	%	102	98	98
Seasonal space heating energy efficiency, warm climate	%	201 / 151	204 / 158	197 / 151
Water heating energy efficiency, warm climate	%	102	98	98
Sound power level L_{WA} outdoors	dB	-	-	-

Data for energy efficiency of the package

Model		F1255-6 1x230V	F1255-12 1x230V
Temperature application	°C	35 / 55	35 / 55
Controller, class		VI	
Controller, contribution to efficiency	%	4	
Seasonal space heating energy efficiency of the package, average climate	%	204 / 154	205 / 161
Seasonal space heating energy efficiency class of the package, average climate		A+++	A+++
Seasonal space heating energy efficiency of the package, cold climate	%	215 / 161	212 / 166
Seasonal space heating energy efficiency of the package, warm climate	%	205 / 155	208 / 162

Model		F1255-6 3x230V	F1255-12 3x230V
Temperature application	°C	35 / 55	35 / 55
Controller, class		VI	
Controller, contribution to efficiency	%	4	
Seasonal space heating energy efficiency of the package, average climate	%	204 / 154	205 / 161
Seasonal space heating energy efficiency class of the package, average climate		A+++	A+++
Seasonal space heating energy efficiency of the package, cold climate	%	215 / 161	212 / 166
Seasonal space heating energy efficiency of the package, warm climate	%	205 / 155	208 / 162

Model		F1255-6 3x400V	F1255-12 3x400V	F1255-16 3x400V
Temperature application	°C	35 / 55	35 / 55	35 / 55
Controller, class		VI		
Controller, contribution to efficiency	%	4		
Seasonal space heating energy efficiency of the package, average climate	%	204 / 154	205 / 161	203 / 158
Seasonal space heating energy efficiency class of the package, average climate		A+++	A+++	A+++
Seasonal space heating energy efficiency of the package, cold climate	%	215 / 161	212 / 166	215 / 163
Seasonal space heating energy efficiency of the package, warm climate	%	205 / 155	208 / 162	201 / 155

The reported efficiency of the package also takes the controller into account. If an external supplementary boiler or solar heating is added to the package, the overall efficiency of the package should be recalculated.

Technical documentation

Model		F1255-6 1x230V					
Type of heat pump	<input type="checkbox"/> Air-water <input type="checkbox"/> Exhaust-water <input checked="" type="checkbox"/> Brine-water <input type="checkbox"/> Water-water						
Low-temperature heat pump	<input type="checkbox"/> Yes <input checked="" type="checkbox"/> No						
Integrated immersion heater for additional heat	<input checked="" type="checkbox"/> Yes <input type="checkbox"/> No						
Heat pump combination heater	<input checked="" type="checkbox"/> Yes <input type="checkbox"/> No						
Climate	<input checked="" type="checkbox"/> Average <input type="checkbox"/> Cold <input type="checkbox"/> Warm						
Temperature application	<input checked="" type="checkbox"/> Average (55 °C) <input type="checkbox"/> Low (35 °C)						
Applied standards	EN-14825 & EN-16147						
Rated heat output	Prated	5,5	kW	Seasonal space heating energy efficiency	η_s	150	%
<i>Declared capacity for space heating at part load and at outdoor temperature T_j</i>				<i>Declared coefficient of performance for space heating at part load and at outdoor temperature T_j</i>			
$T_j = -7\text{ °C}$	Pdh	5.0	kW	$T_j = -7\text{ °C}$	COPd	3.06	-
$T_j = +2\text{ °C}$	Pdh	3.0	kW	$T_j = +2\text{ °C}$	COPd	3.97	-
$T_j = +7\text{ °C}$	Pdh	2.0	kW	$T_j = +7\text{ °C}$	COPd	4.63	-
$T_j = +12\text{ °C}$	Pdh	1.2	kW	$T_j = +12\text{ °C}$	COPd	4.86	-
$T_j = \text{biv}$	Pdh	5.4	kW	$T_j = \text{biv}$	COPd	2.84	-
$T_j = \text{TOL}$	Pdh	5.4	kW	$T_j = \text{TOL}$	COPd	2.84	-
$T_j = -15\text{ °C}$ (if TOL < -20 °C)	Pdh		kW	$T_j = -15\text{ °C}$ (if TOL < -20 °C)	COPd		-
Bivalent temperature	T_{biv}	-10	°C	Min. outdoor air temperature	TOL	-10	°C
Cycling interval capacity	P _{cy}		kW	Cycling interval efficiency	COP _{cy}		-
Degradation coefficient	C _{dh}	0.99	-	Max supply temperature	WTOL	65	°C
<i>Power consumption in modes other than active mode</i>				<i>Additional heat</i>			
Off mode	P_{OFF}	0.002	kW	Rated heat output	P_{sup}	0.1	kW
Thermostat-off mode	P_{TO}	0.007	kW				
Standby mode	P_{SB}	0.007	kW	Type of energy input	Electric		
Crankcase heater mode	P_{CK}	0.009	kW				
<i>Other items</i>							
Capacity control	Variable			Rated airflow (air-water)			m ³ /h
Sound power level, indoors/outdoors	L_{WA}	42 / -	dB	Nominal heating medium flow			m ³ /h
Annual energy consumption	Q_{HE}	2,875	kWh	Brine flow brine-water or water-water heat pumps		0.68	m ³ /h
<i>For heat pump combination heater</i>							
Declared load profile for water heating	XL			Water heating energy efficiency	η_{wh}	102	%
Daily energy consumption	Q_{elec}	7.73	kWh	Daily fuel consumption	Q_{fuel}		kWh
Annual energy consumption	AEC	1,642	kWh	Annual fuel consumption	AFC		GJ
Contact information	NIBE Energy Systems – Box 14 – Hannabadsvägen 5 – 285 21 Markaryd – Sweden						

Model		F1255-12 1x230V					
Type of heat pump	<input type="checkbox"/> Air-water <input type="checkbox"/> Exhaust-water <input checked="" type="checkbox"/> Brine-water <input type="checkbox"/> Water-water						
Low-temperature heat pump	<input type="checkbox"/> Yes <input checked="" type="checkbox"/> No						
Integrated immersion heater for additional heat	<input checked="" type="checkbox"/> Yes <input type="checkbox"/> No						
Heat pump combination heater	<input checked="" type="checkbox"/> Yes <input type="checkbox"/> No						
Climate	<input checked="" type="checkbox"/> Average <input type="checkbox"/> Cold <input type="checkbox"/> Warm						
Temperature application	<input checked="" type="checkbox"/> Average (55 °C) <input type="checkbox"/> Low (35 °C)						
Applied standards	EN-14825 & EN-16147						
Rated heat output	Prated	12,4	kW	Seasonal space heating energy efficiency	η_s	157	%
<i>Declared capacity for space heating at part load and at outdoor temperature T_j</i>				<i>Declared coefficient of performance for space heating at part load and at outdoor temperature T_j</i>			
$T_j = -7\text{ °C}$	Pdh	11.1	kW	$T_j = -7\text{ °C}$	COPd	3.18	-
$T_j = +2\text{ °C}$	Pdh	6.8	kW	$T_j = +2\text{ °C}$	COPd	4.12	-
$T_j = +7\text{ °C}$	Pdh	4.4	kW	$T_j = +7\text{ °C}$	COPd	4.67	-
$T_j = +12\text{ °C}$	Pdh	2.6	kW	$T_j = +12\text{ °C}$	COPd	5.06	-
$T_j = \text{biv}$	Pdh	12.3	kW	$T_j = \text{biv}$	COPd	2.91	-
$T_j = \text{TOL}$	Pdh	12.3	kW	$T_j = \text{TOL}$	COPd	2.91	-
$T_j = -15\text{ °C}$ (if TOL < -20 °C)	Pdh		kW	$T_j = -15\text{ °C}$ (if TOL < -20 °C)	COPd		-
Bivalent temperature	T_{biv}	-10	°C	Min. outdoor air temperature	TOL	-10	°C
Cycling interval capacity	Pcyc		kW	Cycling interval efficiency	COPcyc		-
Degradation coefficient	Cdh	0.99	-	Max supply temperature	WTOL	65	°C
<i>Power consumption in modes other than active mode</i>				<i>Additional heat</i>			
Off mode	P_{OFF}	0.005	kW	Rated heat output	P_{sup}	0.1	kW
Thermostat-off mode	P_{TO}	0.015	kW				
Standby mode	P_{SB}	0.007	kW	Type of energy input	Electric		
Crankcase heater mode	P_{CK}	0.0	kW				
<i>Other items</i>							
Capacity control	Variable			Rated airflow (air-water)			m ³ /h
Sound power level, indoors/outdoors	L_{WA}	44 / -	dB	Nominal heating medium flow			m ³ /h
Annual energy consumption	Q_{HE}	6,213	kWh	Brine flow brine-water or water-water heat pumps		1.46	m ³ /h
<i>For heat pump combination heater</i>							
Declared load profile for water heating	XL			Water heating energy efficiency	η_{wh}	98	%
Daily energy consumption	Q_{elec}	7.78	kWh	Daily fuel consumption	Q_{fuel}		kWh
Annual energy consumption	AEC	1,709	kWh	Annual fuel consumption	AFC		GJ
Contact information	NIBE Energy Systems – Box 14 – Hannabadsvägen 5 – 285 21 Markaryd – Sweden						

Model		F1255-6 3x230V					
Type of heat pump	<input type="checkbox"/> Air-water <input type="checkbox"/> Exhaust-water <input checked="" type="checkbox"/> Brine-water <input type="checkbox"/> Water-water						
Low-temperature heat pump	<input type="checkbox"/> Yes <input checked="" type="checkbox"/> No						
Integrated immersion heater for additional heat	<input checked="" type="checkbox"/> Yes <input type="checkbox"/> No						
Heat pump combination heater	<input checked="" type="checkbox"/> Yes <input type="checkbox"/> No						
Climate	<input checked="" type="checkbox"/> Average <input type="checkbox"/> Cold <input type="checkbox"/> Warm						
Temperature application	<input checked="" type="checkbox"/> Average (55 °C) <input type="checkbox"/> Low (35 °C)						
Applied standards	EN-14825 & EN-16147						
Rated heat output	Prated	5,5	kW	Seasonal space heating energy efficiency	η_s	150	%
<i>Declared capacity for space heating at part load and at outdoor temperature T_j</i>				<i>Declared coefficient of performance for space heating at part load and at outdoor temperature T_j</i>			
$T_j = -7\text{ °C}$	Pdh	5.0	kW	$T_j = -7\text{ °C}$	COPd	3.06	-
$T_j = +2\text{ °C}$	Pdh	3.0	kW	$T_j = +2\text{ °C}$	COPd	3.97	-
$T_j = +7\text{ °C}$	Pdh	2.0	kW	$T_j = +7\text{ °C}$	COPd	4.63	-
$T_j = +12\text{ °C}$	Pdh	1.2	kW	$T_j = +12\text{ °C}$	COPd	4.86	-
$T_j = \text{biv}$	Pdh	5.4	kW	$T_j = \text{biv}$	COPd	2.84	-
$T_j = \text{TOL}$	Pdh	5.4	kW	$T_j = \text{TOL}$	COPd	2.84	-
$T_j = -15\text{ °C}$ (if TOL < -20 °C)	Pdh		kW	$T_j = -15\text{ °C}$ (if TOL < -20 °C)	COPd		-
Bivalent temperature	T_{biv}	-10	°C	Min. outdoor air temperature	TOL	-10	°C
Cycling interval capacity	P _{cyc}		kW	Cycling interval efficiency	COP _{cyc}		-
Degradation coefficient	C _{dh}	0.99	-	Max supply temperature	WTOL	65	°C
<i>Power consumption in modes other than active mode</i>				<i>Additional heat</i>			
Off mode	P _{OFF}	0.002	kW	Rated heat output	P _{sup}	0.1	kW
Thermostat-off mode	P _{TO}	0.007	kW				
Standby mode	P _{SB}	0.007	kW	Type of energy input	Electric		
Crankcase heater mode	P _{CK}	0.009	kW				
<i>Other items</i>							
Capacity control	Variable			Rated airflow (air-water)			
Sound power level, indoors/outdoors	L _{WA}	42 / -	dB	Nominal heating medium flow			
Annual energy consumption	Q _{HE}	2,875	kWh	Brine flow brine-water or water-water heat pumps		0.68	m ³ /h
<i>For heat pump combination heater</i>							
Declared load profile for water heating	XL			Water heating energy efficiency	η_{wh}	102	%
Daily energy consumption	Q _{elec}	7.48	kWh	Daily fuel consumption	Q _{fuel}		kWh
Annual energy consumption	AEC	1,642	kWh	Annual fuel consumption	AFC		GJ
Contact information	NIBE Energy Systems – Box 14 – Hannabadsvägen 5 – 285 21 Markaryd – Sweden						

Model		F1255-12 3x230V					
Type of heat pump	<input type="checkbox"/> Air-water <input type="checkbox"/> Exhaust-water <input checked="" type="checkbox"/> Brine-water <input type="checkbox"/> Water-water						
Low-temperature heat pump	<input type="checkbox"/> Yes <input checked="" type="checkbox"/> No						
Integrated immersion heater for additional heat	<input checked="" type="checkbox"/> Yes <input type="checkbox"/> No						
Heat pump combination heater	<input checked="" type="checkbox"/> Yes <input type="checkbox"/> No						
Climate	<input checked="" type="checkbox"/> Average <input type="checkbox"/> Cold <input type="checkbox"/> Warm						
Temperature application	<input checked="" type="checkbox"/> Average (55 °C) <input type="checkbox"/> Low (35 °C)						
Applied standards	EN-14825 & EN-16147						
Rated heat output	Prated	12,4	kW	Seasonal space heating energy efficiency	η_s	157	%
<i>Declared capacity for space heating at part load and at outdoor temperature T_j</i>				<i>Declared coefficient of performance for space heating at part load and at outdoor temperature T_j</i>			
$T_j = -7\text{ °C}$	Pdh	11.1	kW	$T_j = -7\text{ °C}$	COPd	3.18	-
$T_j = +2\text{ °C}$	Pdh	6.8	kW	$T_j = +2\text{ °C}$	COPd	4.12	-
$T_j = +7\text{ °C}$	Pdh	4.4	kW	$T_j = +7\text{ °C}$	COPd	4.67	-
$T_j = +12\text{ °C}$	Pdh	2.6	kW	$T_j = +12\text{ °C}$	COPd	5.06	-
$T_j = \text{biv}$	Pdh	12.3	kW	$T_j = \text{biv}$	COPd	2.91	-
$T_j = \text{TOL}$	Pdh	12.3	kW	$T_j = \text{TOL}$	COPd	2.91	-
$T_j = -15\text{ °C}$ (if TOL < -20 °C)	Pdh		kW	$T_j = -15\text{ °C}$ (if TOL < -20 °C)	COPd		-
Bivalent temperature	T_{biv}	-10	°C	Min. outdoor air temperature	TOL	-10	°C
Cycling interval capacity	Pcyc		kW	Cycling interval efficiency	COPcyc		-
Degradation coefficient	Cdh	0.99	-	Max supply temperature	WTOL	65	°C
<i>Power consumption in modes other than active mode</i>				<i>Additional heat</i>			
Off mode	P_{OFF}	0.005	kW	Rated heat output	P_{sup}	0.1	kW
Thermostat-off mode	P_{TO}	0.015	kW				
Standby mode	P_{SB}	0.007	kW	Type of energy input	Electric		
Crankcase heater mode	P_{CK}	0.0	kW				
<i>Other items</i>							
Capacity control	Variable			Rated airflow (air-water)			
Sound power level, indoors/outdoors	L_{WA}	44 / -	dB	Nominal heating medium flow			
Annual energy consumption	Q_{HE}	6,213	kWh	Brine flow brine-water or water-water heat pumps		1.46	m^3/h
<i>For heat pump combination heater</i>							
Declared load profile for water heating	XL			Water heating energy efficiency	η_{wh}	98	%
Daily energy consumption	Q_{elec}	7.78	kWh	Daily fuel consumption	Q_{fuel}		kWh
Annual energy consumption	AEC	1,709	kWh	Annual fuel consumption	AFC		GJ
Contact information	NIBE Energy Systems – Box 14 – Hannabadsvägen 5 – 285 21 Markaryd – Sweden						

Model		F1255-6 3x400V					
Type of heat pump	<input type="checkbox"/> Air-water <input type="checkbox"/> Exhaust-water <input checked="" type="checkbox"/> Brine-water <input type="checkbox"/> Water-water						
Low-temperature heat pump	<input type="checkbox"/> Yes <input checked="" type="checkbox"/> No						
Integrated immersion heater for additional heat	<input checked="" type="checkbox"/> Yes <input type="checkbox"/> No						
Heat pump combination heater	<input checked="" type="checkbox"/> Yes <input type="checkbox"/> No						
Climate	<input checked="" type="checkbox"/> Average <input type="checkbox"/> Cold <input type="checkbox"/> Warm						
Temperature application	<input checked="" type="checkbox"/> Average (55 °C) <input type="checkbox"/> Low (35 °C)						
Applied standards	EN-14825 & EN-16147						
Rated heat output	Prated	5,5	kW	Seasonal space heating energy efficiency	η_s	150	%
<i>Declared capacity for space heating at part load and at outdoor temperature T_j</i>				<i>Declared coefficient of performance for space heating at part load and at outdoor temperature T_j</i>			
$T_j = -7\text{ °C}$	Pdh	5.0	kW	$T_j = -7\text{ °C}$	COPd	3.06	-
$T_j = +2\text{ °C}$	Pdh	3.0	kW	$T_j = +2\text{ °C}$	COPd	3.97	-
$T_j = +7\text{ °C}$	Pdh	2.0	kW	$T_j = +7\text{ °C}$	COPd	4.63	-
$T_j = +12\text{ °C}$	Pdh	1.2	kW	$T_j = +12\text{ °C}$	COPd	4.86	-
$T_j = \text{biv}$	Pdh	5.4	kW	$T_j = \text{biv}$	COPd	2.84	-
$T_j = \text{TOL}$	Pdh	5.4	kW	$T_j = \text{TOL}$	COPd	2.84	-
$T_j = -15\text{ °C}$ (if TOL < -20 °C)	Pdh		kW	$T_j = -15\text{ °C}$ (if TOL < -20 °C)	COPd		-
Bivalent temperature	T_{biv}	-10	°C	Min. outdoor air temperature	TOL	-10	°C
Cycling interval capacity	P _{cych}		kW	Cycling interval efficiency	COP _{cyc}		-
Degradation coefficient	Cdh	0.99	-	Max supply temperature	WTOL	65	°C
<i>Power consumption in modes other than active mode</i>				<i>Additional heat</i>			
Off mode	P _{OFF}	0.002	kW	Rated heat output	P _{sup}	0.1	kW
Thermostat-off mode	P _{TO}	0.007	kW				
Standby mode	P _{SB}	0.007	kW	Type of energy input	Electric		
Crankcase heater mode	P _{CK}	0.009	kW				
<i>Other items</i>							
Capacity control	Variable			Rated airflow (air-water)			
Sound power level, indoors/outdoors	L _{WA}	42 / -	dB	Nominal heating medium flow			
Annual energy consumption	Q _{HE}	2,875	kWh	Brine flow brine-water or water-water heat pumps		0.68	m ³ /h
<i>For heat pump combination heater</i>							
Declared load profile for water heating	XL			Water heating energy efficiency	η_{wh}	102	%
Daily energy consumption	Q _{elec}	7.48	kWh	Daily fuel consumption	Q _{fuel}		kWh
Annual energy consumption	AEC	1,642	kWh	Annual fuel consumption	AFC		GJ
Contact information	NIBE Energy Systems – Box 14 – Hannabadsvägen 5 – 285 21 Markaryd – Sweden						

Model		F1255-12 3x400V					
Type of heat pump	<input type="checkbox"/> Air-water <input type="checkbox"/> Exhaust-water <input checked="" type="checkbox"/> Brine-water <input type="checkbox"/> Water-water						
Low-temperature heat pump	<input type="checkbox"/> Yes <input checked="" type="checkbox"/> No						
Integrated immersion heater for additional heat	<input checked="" type="checkbox"/> Yes <input type="checkbox"/> No						
Heat pump combination heater	<input checked="" type="checkbox"/> Yes <input type="checkbox"/> No						
Climate	<input checked="" type="checkbox"/> Average <input type="checkbox"/> Cold <input type="checkbox"/> Warm						
Temperature application	<input checked="" type="checkbox"/> Average (55 °C) <input type="checkbox"/> Low (35 °C)						
Applied standards	EN-14825 & EN-16147						
Rated heat output	Prated	12,4	kW	Seasonal space heating energy efficiency	η_s	157	%
<i>Declared capacity for space heating at part load and at outdoor temperature T_j</i>				<i>Declared coefficient of performance for space heating at part load and at outdoor temperature T_j</i>			
$T_j = -7\text{ °C}$	Pdh	11.1	kW	$T_j = -7\text{ °C}$	COPd	3.18	-
$T_j = +2\text{ °C}$	Pdh	6.8	kW	$T_j = +2\text{ °C}$	COPd	4.12	-
$T_j = +7\text{ °C}$	Pdh	4.4	kW	$T_j = +7\text{ °C}$	COPd	4.67	-
$T_j = +12\text{ °C}$	Pdh	2.6	kW	$T_j = +12\text{ °C}$	COPd	5.06	-
$T_j = \text{biv}$	Pdh	12.3	kW	$T_j = \text{biv}$	COPd	2.91	-
$T_j = \text{TOL}$	Pdh	12.3	kW	$T_j = \text{TOL}$	COPd	2.91	-
$T_j = -15\text{ °C}$ (if TOL < -20 °C)	Pdh		kW	$T_j = -15\text{ °C}$ (if TOL < -20 °C)	COPd		-
Bivalent temperature	T_{biv}	-10	°C	Min. outdoor air temperature	TOL	-10	°C
Cycling interval capacity	P _{cyh}		kW	Cycling interval efficiency	COP _{cy}		-
Degradation coefficient	Cdh	0.99	-	Max supply temperature	WTOL	65	°C
<i>Power consumption in modes other than active mode</i>				<i>Additional heat</i>			
Off mode	P _{OFF}	0.005	kW	Rated heat output	P _{sup}	0.1	kW
Thermostat-off mode	P _{TO}	0.015	kW				
Standby mode	P _{SB}	0.007	kW	Type of energy input	Electric		
Crankcase heater mode	P _{CK}	0.0	kW				
<i>Other items</i>							
Capacity control	Variable			Rated airflow (air-water)			
Sound power level, indoors/outdoors	L _{WA}	44 / -	dB	Nominal heating medium flow			
Annual energy consumption	Q _{HE}	6,213	kWh	Brine flow brine-water or water-water heat pumps		1.46	m ³ /h
<i>For heat pump combination heater</i>							
Declared load profile for water heating	XL			Water heating energy efficiency	η_{wh}	98	%
Daily energy consumption	Q _{elec}	7.78	kWh	Daily fuel consumption	Q _{fuel}		kWh
Annual energy consumption	AEC	1,709	kWh	Annual fuel consumption	AFC		GJ
Contact information	NIBE Energy Systems – Box 14 – Hannabadsvägen 5 – 285 21 Markaryd – Sweden						

Model		F1255-16 3x400V					
Type of heat pump	<input type="checkbox"/> Air-water <input type="checkbox"/> Exhaust-water <input checked="" type="checkbox"/> Brine-water <input type="checkbox"/> Water-water						
Low-temperature heat pump	<input type="checkbox"/> Yes <input checked="" type="checkbox"/> No						
Integrated immersion heater for additional heat	<input checked="" type="checkbox"/> Yes <input type="checkbox"/> No						
Heat pump combination heater	<input checked="" type="checkbox"/> Yes <input type="checkbox"/> No						
Climate	<input checked="" type="checkbox"/> Average <input type="checkbox"/> Cold <input type="checkbox"/> Warm						
Temperature application	<input checked="" type="checkbox"/> Average (55 °C) <input type="checkbox"/> Low (35 °C)						
Applied standards	EN-14825 & EN-16147						
Rated heat output	Prated	16,0	kW	Seasonal space heating energy efficiency	η_s	154	%
<i>Declared capacity for space heating at part load and at outdoor temperature T_j</i>				<i>Declared coefficient of performance for space heating at part load and at outdoor temperature T_j</i>			
$T_j = -7\text{ °C}$	Pdh	14.2	kW	$T_j = -7\text{ °C}$	COPd	3.0	-
$T_j = +2\text{ °C}$	Pdh	8.7	kW	$T_j = +2\text{ °C}$	COPd	4.1	-
$T_j = +7\text{ °C}$	Pdh	5.6	kW	$T_j = +7\text{ °C}$	COPd	4.9	-
$T_j = +12\text{ °C}$	Pdh	5.5	kW	$T_j = +12\text{ °C}$	COPd	5.0	-
$T_j = \text{biv}$	Pdh	15.4	kW	$T_j = \text{biv}$	COPd	2.8	-
$T_j = \text{TOL}$	Pdh	15.4	kW	$T_j = \text{TOL}$	COPd	2.8	-
$T_j = -15\text{ °C}$ (if TOL < -20 °C)	Pdh		kW	$T_j = -15\text{ °C}$ (if TOL < -20 °C)	COPd		-
Bivalent temperature	T_{biv}	-10	°C	Min. outdoor air temperature	TOL	-10	°C
Cycling interval capacity	P _{cyc}		kW	Cycling interval efficiency	COP _{cyc}		-
Degradation coefficient	Cdh	0.99	-	Max supply temperature	WTOL	65	°C
<i>Power consumption in modes other than active mode</i>				<i>Additional heat</i>			
Off mode	P _{OFF}	0.002	kW	Rated heat output	P _{sup}	0.6	kW
Thermostat-off mode	P _{TO}	0.020	kW				
Standby mode	P _{SB}	0.007	kW	Type of energy input	Electric		
Crankcase heater mode	P _{CK}	0.030	kW				
<i>Other items</i>							
Capacity control	Variable			Rated airflow (air-water)			m ³ /h
Sound power level, indoors/outdoors	L _{WA}	42 / -	dB	Nominal heating medium flow			m ³ /h
Annual energy consumption	Q _{HE}	8,167	kWh	Brine flow brine-water or water-water heat pumps		1.84	m ³ /h
<i>For heat pump combination heater</i>							
Declared load profile for water heating	XL			Water heating energy efficiency	η_{wh}	98	%
Daily energy consumption	Q _{elec}	7.78	kWh	Daily fuel consumption	Q _{fuel}		kWh
Annual energy consumption	AEC	1,709	kWh	Annual fuel consumption	AFC		GJ
Contact information	NIBE Energy Systems – Box 14 – Hannabadsvägen 5 – 285 21 Markaryd – Sweden						

13 Item register

Item register

A

Accessibility, electrical connection, 19
Accessories, 62
Alarm, 60
Assembly, 6

B

Back button, 38
Brine side, 15

C

Cable lock, 20
Commissioning and adjusting, 32
 Filling and venting, 32
 Post adjustment and bleeding, 34
 Preparations, 32
 Start guide, 33
Connecting accessories, 30
Connecting current sensors, 26
Connecting external operating voltage for the control system, 21
Connecting the climate system, 16
Connecting the hot water heater, 16
Connections, 21
Connector for +Adjust, 28
Contact for activation of fan speed, 29
Contact for activation of "external adjustment", 29
Contact for activation of "temporary lux", 29
Contact for external tariff blocking, 28
Control, 38, 42
 Control - Introduction, 38
 Control - Menus, 42
Control - Introduction, 38
 Display unit, 38
 Menu system, 39
Control knob, 38
Controlling ground water pump, 30
Control - Menus, 42
 Menu 5 - SERVICE, 44
Cooling mode indication, 30
Cooling section, 12

D

Data for energy efficiency of the system, 74
Delivery and handling, 6
 Assembly, 6
 Drawing out the cooling module, 6
 Installation area, 6
 Removing parts of the insulation, 8
 Removing the covers, 7
 Supplied components, 7
 Transport, 6
Diagram, dimensioning compressor speed, 69
Dimensions and pipe connections, 15
Dimensions and setting-out coordinates, 64
Display, 38
Display unit, 38
 Back button, 38
 Control knob, 38
 Display, 38
 OK button, 38
 Status lamp, 38
 Switch, 38
Disturbances in comfort, 60
 Alarm, 60
 Manage alarm, 60
 Troubleshooting, 60
Docking alternatives, 16
 Extra electric hot water heater, 17

Free cooling, 18
Ground water system, 17
Neutralization vessel, 16
Pool, 18
 Two or more climate systems, 18
Under floor heating systems, 18
Ventilation recovery, 17
Draining the climate system, 55
Draining the hot water heater, 55
Drawing out the cooling module, 6, 56

E

Electrical addition - maximum output, 23
 Setting max electrical output, 23
 Switching to maximum electrical output, 23
Electrical cabinets, 11
Electrical connections, 19
 Accessibility, electrical connection, 19
 Cable lock, 20
 Connecting accessories, 30
 Connecting external operating voltage for the control system, 21
 Connections, 21
 Electrical addition - maximum output, 23
 External connection options, 27
 General, 19
 Load monitor, 26
 Miniature circuit-breaker, 19
 Optional connections, 26
 Outdoor sensor, 22
 Power connection, 21
 Removing the cover, base board, 20
 Removing the cover, immersion heater circuit board, 20
 Removing the hatch, input circuit board, 20
 Room sensor, 22
 Settings, 23
 Standby mode, 24
 Temperature limiter, 19
 Temperature sensor, external flow line, 22
 Uplink, 27
Emptying the brine system, 55
Energy labelling, 71
 Data for energy efficiency of the package, 74
 Information sheet, 71–73
 Technical documentation, 75, 77, 79
External connection options, 27
 Connector for +Adjust, 28
 Contact for activation of fan speed, 29
 Contact for activation of "economy", 29
 Contact for activation of "external adjustment", 29
 Contact for activation of "temporary lux", 29
 Contact for external tariff blocking, 28
 Controlling ground water pump, 30
 Cooling mode indication, 30
 Extra circulation pump, 30
 Hot water circulation, 30
 NV 10, pressure/level/flow monitor brine, 29
 Possible selection for AUX inputs, 28
 Possible selection for AUX output (potential free variable relay), 30
 Switch for "Smart Grid ready", 28
 Switch for external blocking of addition and/or compressor, 28
 Switch for external blocking of heating, 29
 Switch for external forced control of brine pump, 29
 Temperature sensor, cooling/heating, 28
Extra circulation pump, 30

- F**
- Filling and venting, 32
 - Filling and venting the brine system, 32
 - Filling and venting the climate system, 32
 - Filling the hot water heater, 32
 - Symbol key, 33
- Filling and venting the brine system, 32
- Filling and venting the climate system, 32
- Filling the hot water heater, 32
- H**
- Heating medium side, 16
 - Connecting the climate system, 16
- Helping the circulation pump to start, 56
- Help menu, 34, 41
- Hot water circulation, 30
- Hot water heater, 16
 - Connecting the hot water heater, 16
- I**
- Important information, 4
 - Recovery, 4
- Information sheet, 71
- Inspection of the installation, 5
- Installation area, 6
- M**
- Manage alarm, 60
- Marking, 4
- Menu 5 - SERVICE, 44
- Menu system, 39
 - Help menu, 34, 41
 - Operation, 40
 - Scroll through the windows, 41
 - Selecting menu, 40
 - Selecting options, 40
 - Setting a value, 40
 - Use the virtual keyboard, 41
- Miniature circuit-breaker, 19
- N**
- NV 10, pressure/level/flow monitor brine, 29
- O**
- OK button, 38
- Operation, 40
- Optional connections, 26
- Outdoor sensor, 22
- P**
- Pipe and ventilation connections
 - Symbol key, 14
- Pipe connections, 14
 - Brine side, 15
 - Dimensions and pipe connections, 15
 - Docking alternatives, 16
 - General, 14
 - Heating medium side, 16
 - Hot water heater, 16
 - Pipe dimensions, 15
 - System diagram, 14
- Pipe dimensions, 15
- Possible selection for AUX inputs, 28
- Possible selection for AUX output (potential free variable relay), 30
- Post adjusting the room temperature, 35
- Post adjustment and bleeding, 34
 - Post adjusting the room temperature, 35
 - Pump adjustment, automatic operation, 34
 - Pump adjustment, manual operation, 34
 - Pump capacity diagram, brine side, manual operation, 34
 - Readjusting, venting, heat medium side, 35
- Power connection, 21
- Preparations, 32
- Pump adjustment, automatic operation, 34
 - Brine side, 34
 - Heating medium side, 34
- Pump adjustment, manual operation, 34
 - Heating medium side, 34
- Pump capacity diagram, brine side, manual operation, 34
- R**
- Readjusting, venting, heat medium side, 35
- Remove parts of the insulation, 8
- Removing the cover, base board, 20
- Removing the cover, immersion heater circuit board, 20
- Removing the covers, 7
- Removing the hatch, input circuit board, 20
- Room sensor, 22
- S**
- Safety information
 - Inspection of the installation, 5
 - Marking, 4
 - Serial number, 4
 - Symbols, 4
 - Symbols on F1255, 4
- Scroll through the windows, 41
- Selecting menu, 40
- Selecting options, 40
- Serial number, 4
- Service, 54
 - Service actions, 54
- Service actions, 54
 - Draining the climate system, 55
 - Draining the hot water heater, 55
 - Drawing out the cooling module, 56
 - Emptying the brine system, 55
 - Helping the circulation pump to start, 56
 - Standby mode, 54
 - Temperature sensor data, 56
 - USB service outlet, 58
- Setting a value, 40
- Settings, 23
- Standby mode, 54
 - Power in emergency mode, 24
- Start guide, 33
- Status lamp, 38
- Supplied components, 7
- Switch, 38
- Switch for "Smart Grid ready", 28
- Switch for external blocking of addition and/or compressor, 28
- Switch for external blocking of heating, 29
- Switch for external forced control of brine pump, 29
- Symbol key, 14, 33
- Symbols, 4
- Symbols on F1255, 4
- System diagram, 14
- T**
- Technical data, 64
 - Dimensions and setting-out coordinates, 64
 - Energy labelling, 71
 - Data for energy efficiency of the system, 74
 - Information sheet, 71
 - Technical documentation, 75
 - Technical Data, 65
- Technical Data, 65
 - Diagram, dimensioning compressor speed, 69
 - Working range heat pump, 68
- Technical documentation, 75
- Temperature limiter, 19
 - Resetting, 19
- Temperature sensor, cooling/heating, 28
- Temperature sensor, external flow line, 22
- Temperature sensor data, 56

- The heat pump design, 9
 - Component list cooling section, 12
 - Component list electrical cabinets, 11
 - Component location cooling section, 12
 - Component location electrical cabinets, 11
 - Component locations, 9
 - List of components, 9
- Transport, 6
- Troubleshooting, 60

U

- Uplink, 27
- USB service outlet, 58
- Use the virtual keyboard, 41

W

- Working range heat pump, 68

Contact information

- AT** **KNV Energietechnik GmbH**, Gahberggasse 11, AT-4861 Schörfling
Tel: +43 (0)7662 8963 E-mail: mail@knv.at www.knv.at
- CH** **NIBE Wärmetechnik c/o ait Schweiz AG**, Industriepark, CH-6246 Altishofen
Tel: +41 58 252 21 00 E-mail: info@nibe.ch www.nibe.ch
- CZ** **Druzstevni zavody Drazice s.r.o.**, Drazice 69, CZ - 294 71 Benátky nad Jizerou
Tel: +420 326 373 801 E-mail: nibe@nibe.cz www.nibe.cz
- DE** **NIBE Systemtechnik GmbH**, Am Reiherpfahl 3, 29223 Celle
Tel: +49 (0)5141 7546-0 E-mail: info@nibe.de www.nibe.de
- DK** **Vølund Varmeteknik A/S**, Member of the Nibe Group, Brogårdsvej 7, 6920 Videbæk
Tel: +45 97 17 20 33 E-mail: info@volundvt.dk www.volundvt.dk
- FI** **NIBE Energy Systems OY**, Juurakkotie 3, 01510 Vantaa
Tel: +358 (0)9-274 6970 E-mail: info@nibe.fi www.nibe.fi
- FR** **NIBE Energy Systems France Sarl**, Zone industrielle RD 28, Rue du Pou du Ciel, 01600 Reyrieux
Tel : 04 74 00 92 92 E-mail: info@nibe.fr www.nibe.fr
- GB** **NIBE Energy Systems Ltd**, 3C Broom Business Park, Bridge Way, S419QG Chesterfield
Tel: +44 (0)845 095 1200 E-mail: info@nibe.co.uk www.nibe.co.uk
- NL** **NIBE Energietechniek B.V.**, Postbus 634, NL 4900 AP Oosterhout
Tel: 0168 477722 E-mail: info@nibenl.nl www.nibenl.nl
- NO** **ABK AS**, Brobekkveien 80, 0582 Oslo, Postadresse: Postboks 64 Vollebekk, 0516 Oslo
Tel: +47 23 17 05 20 E-mail: post@abkklima.no www.nibe.no
- PL** **NIBE-BIAWAR Sp. z o. o.** Aleja Jana Pawła II 57, 15-703 BIALYSTOK
Tel: +48 (0)85 662 84 90 E-mail: sekretariat@biawar.com.pl www.biawar.com.pl
- RU** © "EVAN" 17, per. Boynovskiy, RU-603024 Nizhny Novgorod
Tel: +7 831 419 57 06 E-mail: kuzmin@evan.ru www.nibe-evan.ru
- SE** **NIBE AB Sweden**, Box 14, Hannabadsvägen 5, SE-285 21 Markaryd
Tel: +46 (0)433 73 000 E-mail: info@nibe.se www.nibe.se

For countries not mention in this list, please contact Nibe Sweden or check www.nibe.eu for more information.

NIBE AB Sweden
Hannabadsvägen 5
Box 14
SE-285 21 Markaryd
info@nibe.se
www.nibe.eu

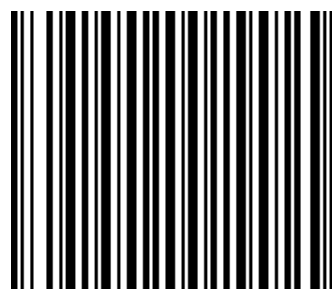

331296